

SECTION A-A

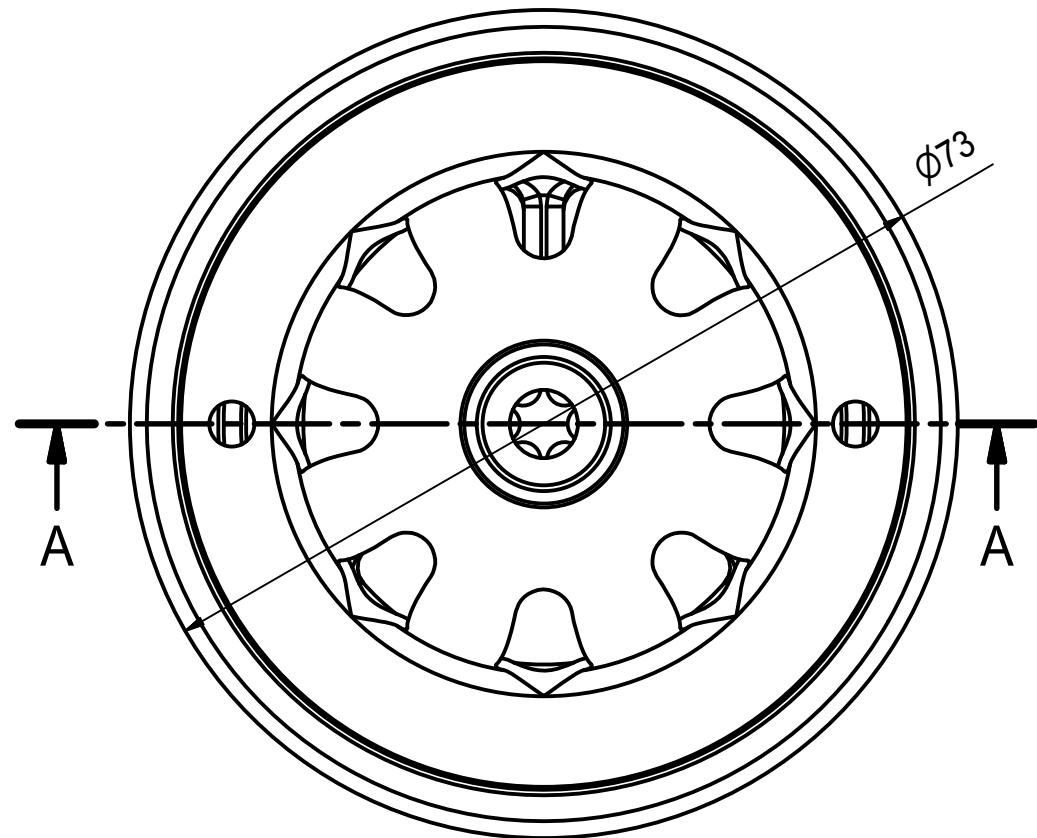

TOP VIEW

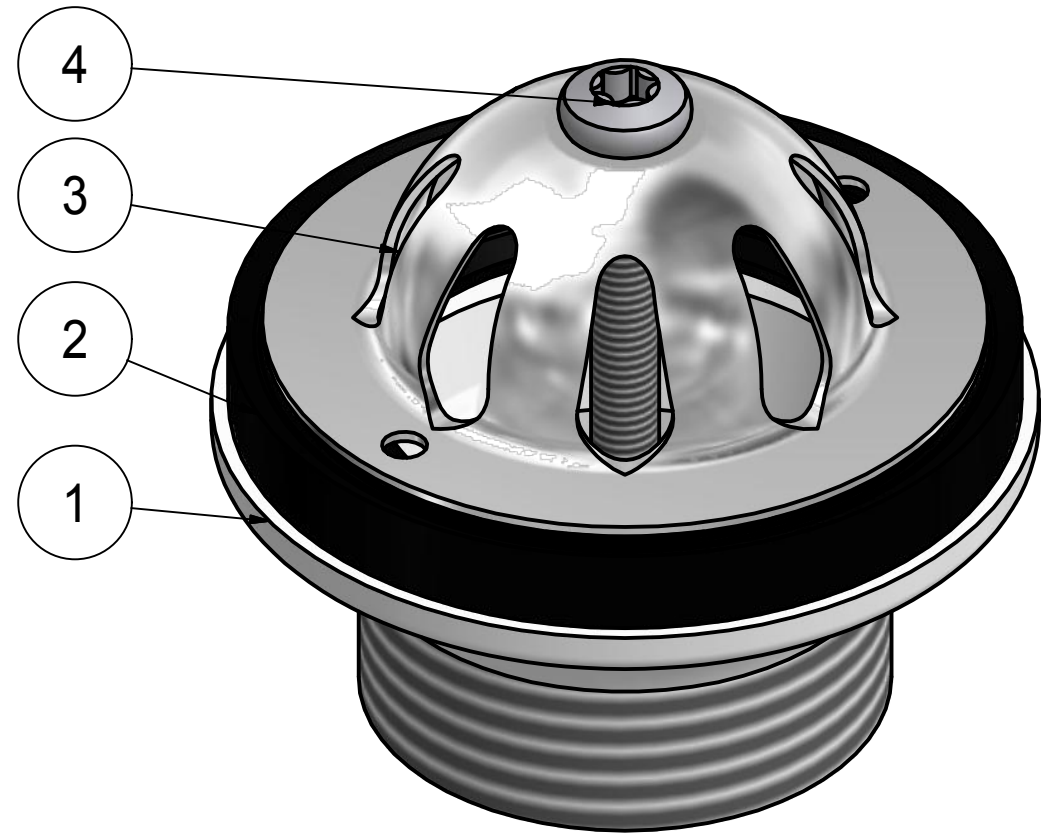



1	Waste Outlet	1	Plastic			0084-123021	
1	Gasket	2	Rubber			0084-123022	
1	Dome	3	304N04			0084-123311	
1	M6 x 50mm SS Screw	4	304N04			0084-123313	
Qty	Title	Item	Material	Part	Part Number	Drawing No.	Remark

Parts List

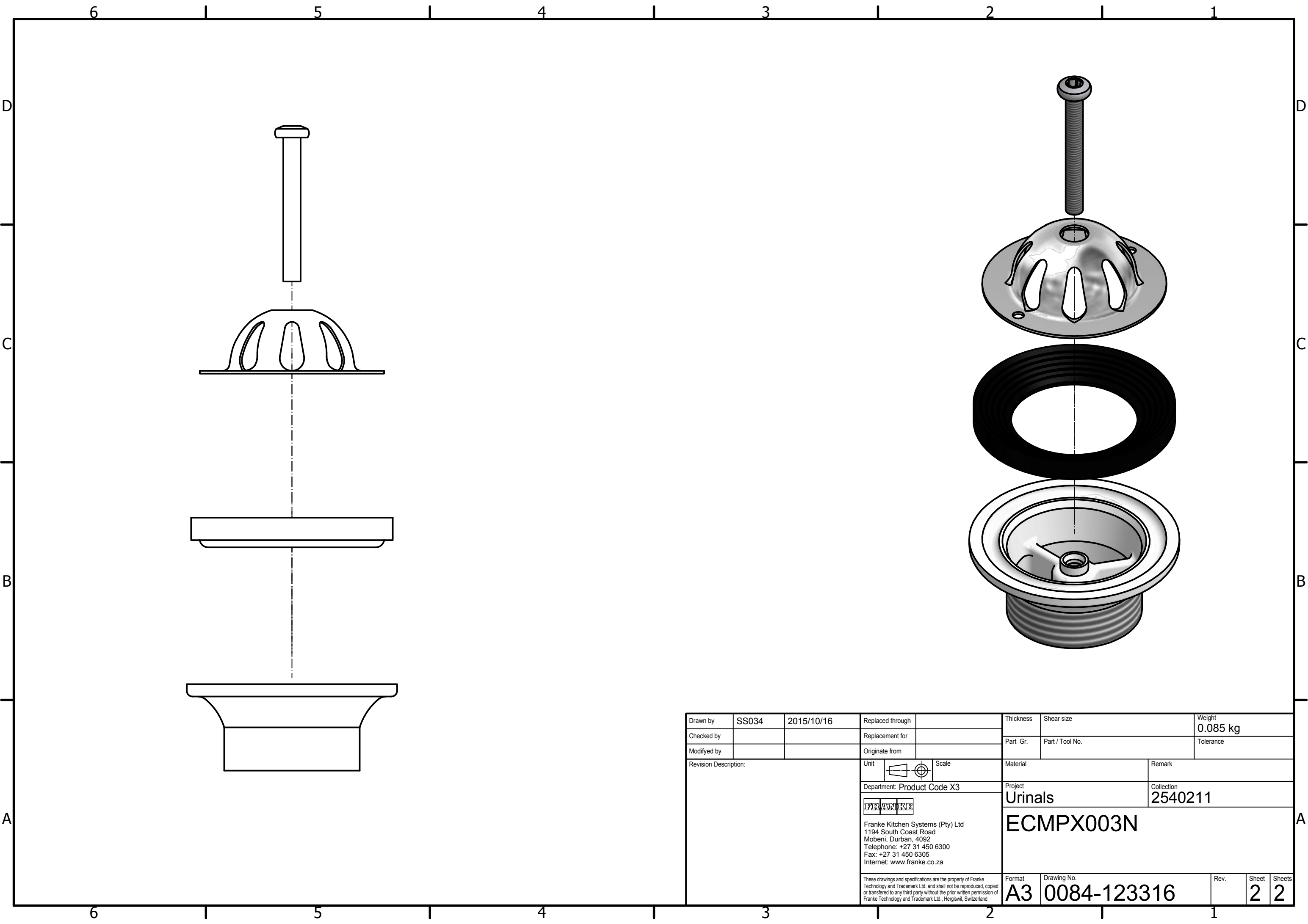
Drawn by	SS034	2015/10/16	Replaced through		Thickness	Shear size	Weight	0.085 kg
Checked by			Replacement for		Part Gr.	Part / Tool No.	Tolerance	
Modified by			Originate from		Unit	Scale	Material	Remark
Revision Description:			Department: Product Code X3		Project		Collection	
					Urinals		2540211	
			Franke Kitchen Systems (Pty) Ltd 1194 South Coast Road Mobeni, Durban, 4092 Telephone: +27 31 450 6300 Fax: +27 31 450 6305 Internet: www.franke.co.za		ECMPX003N			
			<small>These drawings and specifications are the property of Franke Technology and Trademark Ltd. and shall not be reproduced, copied or transferred to any third party without the prior written permission of Franke Technology and Trademark Ltd., Hergiswil, Switzerland</small>		Format	Drawing No.	Rev.	Sheet
					A3	0084-123316		1
								2



Drawn by	SS034	2015/10/16	Replaced through		Thickness	Shear size	Weight	0.085 kg
Checked by			Replacement for		Part Gr.	Part / Tool No.	Tolerance	
Modified by			Originate from		Unit  Scale		Material	Remark
Revision Description:			Department: Product Code X3		Project		Collection	
					Urinals		2540211	
			Franke Kitchen Systems (Pty) Ltd 1194 South Coast Road Mobeni, Durban, 4092 Telephone: +27 31 450 6300 Fax: +27 31 450 6305 Internet: www.franke.co.za		ECMPX003N			
			<small>These drawings and specifications are the property of Franke Technology and Trademark Ltd. and shall not be reproduced, copied or transferred to any third party without the prior written permission of Franke Technology and Trademark Ltd., Hergiswil, Switzerland</small>		Format	Drawing No.	Rev.	Sheet
		A3	0084-123316		2	2		