

F5

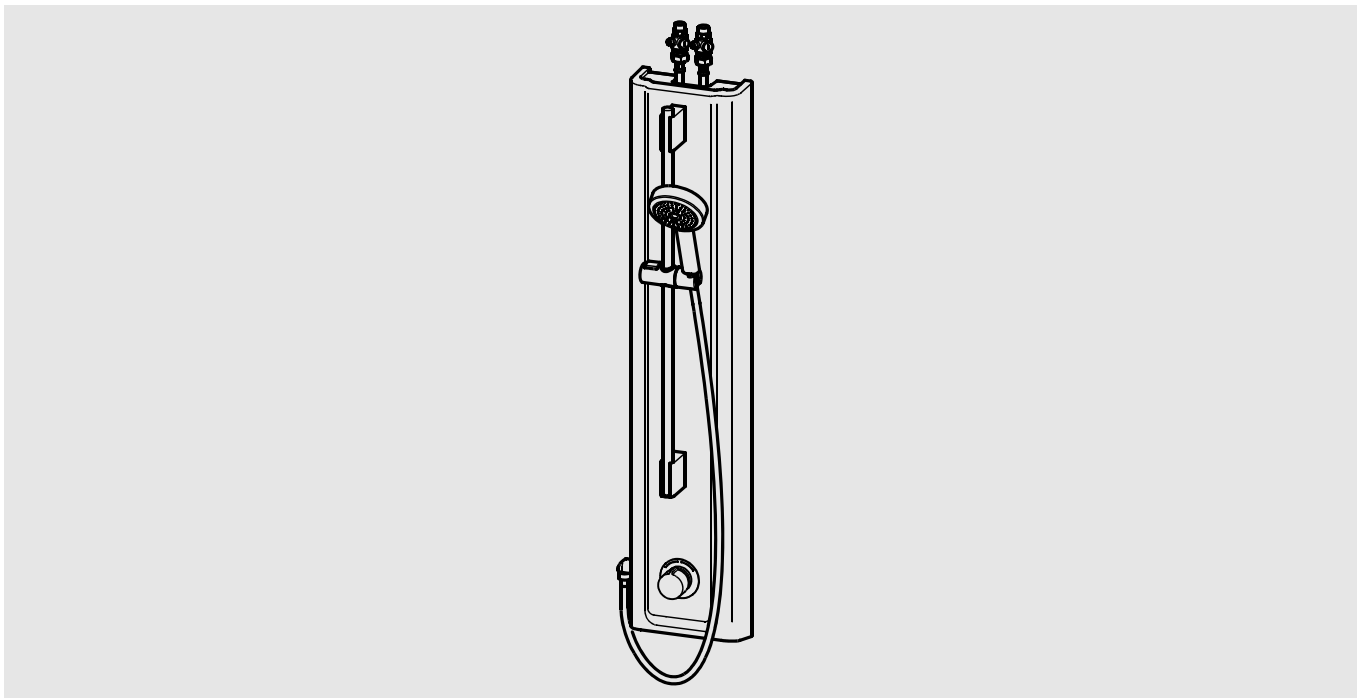

F5SM2025
2030056550

DE	Montage- und Betriebsanleitung	Duschpaneel MIRANIT
EN	Installation and operating instructions	Shower panel MIRANIT
FR	Notice de montage et de mise en service	Panneau de douche MIRANIT
ES	Instrucciones de montaje y servicio	Panel de ducha de MIRANIT
IT	Istruzioni per il montaggio e l'uso	Pannello doccia MIRANIT
NL	Montage- en bedrijfsinstructies	douchepaneel MIRANIT
PL	Instrukcja montażu i obsługi	Panel natryskowy MIRANIT
SV	Monterings- och driftinstruktion	Dusch panel MIRANIT
CS	Návod pro montáž a provoz	Sprchový panel MIRANIT
FI	Asennus- ja käyttöohje	Suihkupaneeli MIRANIT
RU	Инструкция по монтажу и вводу в эксплуатацию	

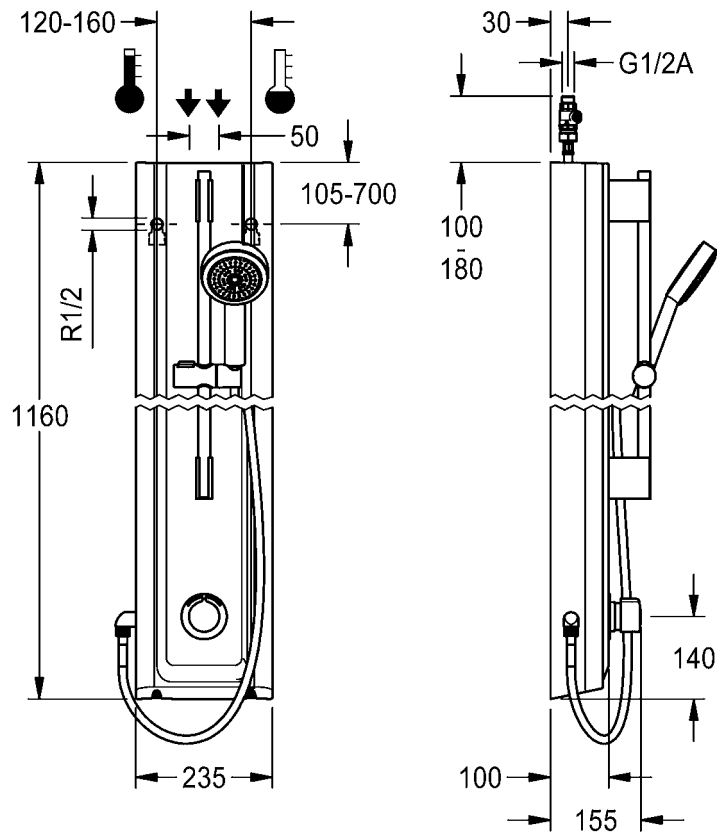
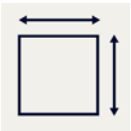
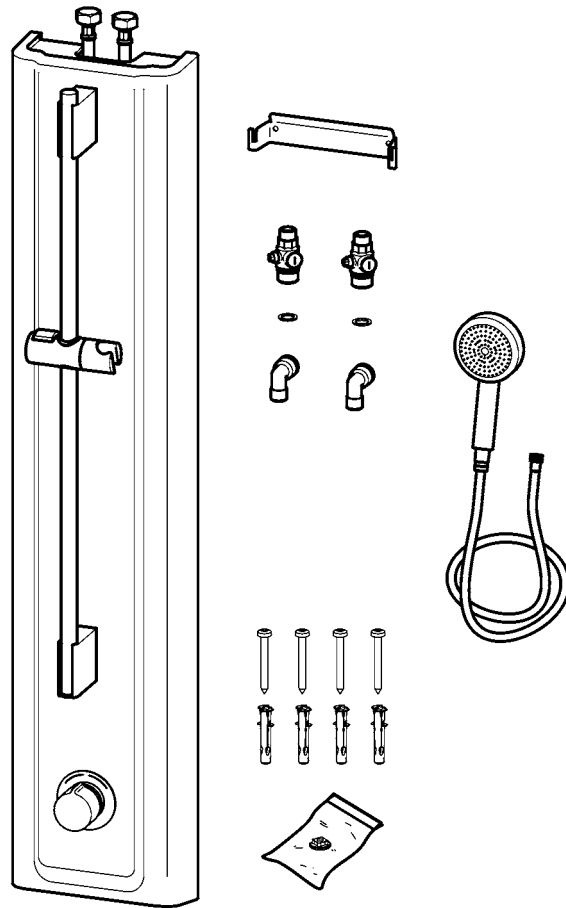

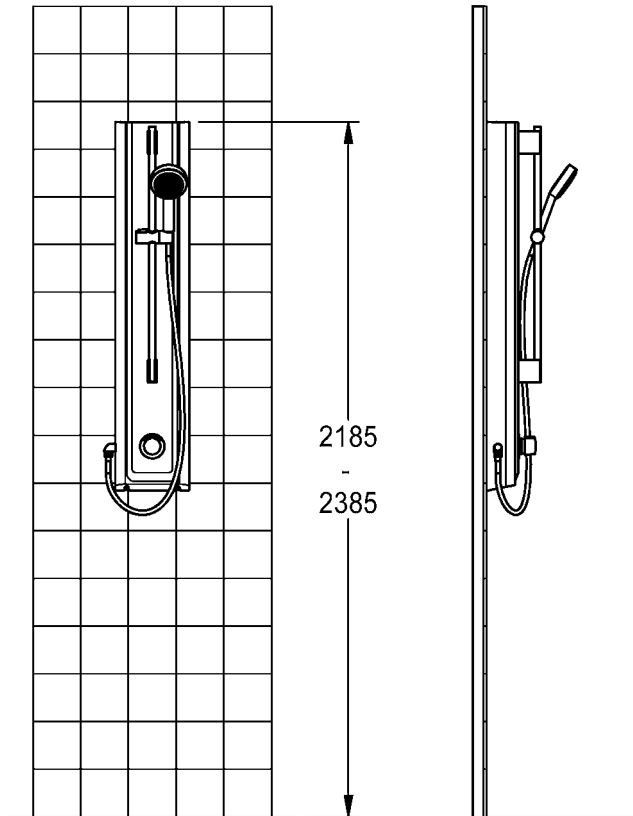
**EN**

Installation and operating instructions

Important notes

- ▶ Before installing flush piping system!
- ▶ Set the temperature stop after assembly has been completed.
- ▶ The fitting must be operated only with original mesh filters and return flow inhibitors!
- ▶ The fitting must be checked and maintained at regular intervals depending on the water quality and in accordance with the local conditions, and rules and regulations applicable at the site.

Technical data

- ▶ Minimum flow pressure 1.0 bar
- ▶ Maximum operating pressure 10 bar
- ▶ Recommended flow pressure 3 bar
- ▶ Volume flow at 3 bar flow pressure 9 l/min
- ▶ Flow time at 38 °C 5-35 s, adjustable

DE

Montage- und Betriebsanleitung

Wichtige Hinweise

- ▶ Vor Installation Rohrleitungen spülen!
- ▶ Nach erfolgter Montage den Temperaturanschlag einstellen.
- ▶ Armatur nur mit original Sieben und Rückflussverhinderern betreiben!
- ▶ In Abhängigkeit von der Wasserqualität, den örtlichen Gegebenheiten und den vor Ort geltenden Bestimmungen die Armatur in regelmäßigen Abständen prüfen und warten.

Technische Daten

- ▶ Mindestfließdruck 1,0 bar
- ▶ Maximaler Betriebsdruck 10 bar
- ▶ Empfohlener Fließdruck 3 bar
- ▶ Volumenstrom bei 3 bar Fließdruck 9 l/min
- ▶ Fließzeit bei 38 °C 5-35 s, einstellbar

PL

Instrukcja montażu i obsługi

Ważne wskazówki

- ▶ Przed instalacją przepłukać rury!
- ▶ Po przeprowadzeniu montażu ustawić ograniczenie temperatury.
- ▶ Armatury należy używać wyłącznie z oryginalnymi sitkami i zaworami zwrotnymi!
- ▶ Armaturę należy poddawać regularnej kontroli i konserwacji w zależności od jakości wody, warunków lokalnych i obowiązujących przepisów.

Dane techniczne

- ▶ Minimalne ciśnienie przepływu 1,0 bar
- ▶ Maksymalne ciśnienie robocze 10 barów
- ▶ Zalecane ciśnienie przepływu 3 barów
- ▶ Objętościowe natężenie przepływu przy ciśnieniu 3 barów 9 l/min
- ▶ Czas przepływu w temp. 38 °C 5-35 s, z możliwością ustawienia

FR

Notice de montage et de mise en service

Remarques importantes

- ▶ Rincer les conduites avant d'installer !
- ▶ Régler la butée de température après le montage.
- ▶ Ne faire fonctionner la robinetterie qu'avec les filtres et clapets de non retour d'origine !
- ▶ En fonction de la qualité de l'eau, ainsi que des conditions et des dispositions locales, il convient de contrôler et d'entretenir la robinetterie à intervalles réguliers.

Données techniques

- ▶ Pression dynamique minimale 1,0 bar
- ▶ Pression de service maximale 10 bars
- ▶ Pression dynamique recommandée 3 bars
- ▶ Débit volumique pour 3 bars de pression dynamique 9 l/min
- ▶ Temps d'écoulement à 38 °C 5-35 s, réglable

SV

Monterings- och driftinstruktion

Viktiga informationer

- ▶ Spola igenom rörledningarna före installation!
- ▶ Ställ in temperaturstoppet efter installationen.
- ▶ Använd armaturen endast med originalsilar och originalåterflödesförhindrare!
- ▶ Kontrollera och serva armaturen med intervaller som bestäms av vattenkvaliteten samt de lokala förhållandena och de bestämmelser som gäller där.

Tekniska data

- ▶ Minsta hydrauliska tryck 1,0 bar
- ▶ Maximalt driftryck 10 bar
- ▶ Rekommenderat hydrauliskt tryck 3 bar
- ▶ Volymström vid 3 bar hydrauliskt tryck 9 l/min
- ▶ Flytförmåga vid 38 °C 5-35 s, inställbar

CS

Návod pro montáž a provoz

Důležité pokyny

- ▶ Před instalací potrubí propláchněte!
- ▶ Po montáži nastavte teplotní limit.
- ▶ Provozovat armaturu jen s originálními sítky a zařízeními proti zpětnému toku!
- ▶ V závislosti na kvalitě vody, místních podmínkách a předpisech platných v místě instalace je nutné provádět v pravidelných intervalech kontrolu a údržbu armatury.

Technické údaje

- ▶ Minimální průtočný tlak 1,0 bar
- ▶ Maximální provozní tlak 10 bar
- ▶ Doporučený průtočný tlak 3 bar
- ▶ Průtok při průtočném tlaku 3 bar 9 l/min
- ▶ Doba průtoku při 38 °C 5-35 s, nastavitelná

ES

Instrucciones de montaje y servicio

Indicaciones importantes

- ▶ ¡Enjuagar las tuberías antes de instalar!
- ▶ Tras finalizar el montaje, ajustar el tope de temperatura.
- ▶ ¡La grifería debe hacerse funcionar únicamente con los tamices y las válvulas antiretorno originales!
- ▶ En función de la calidad del agua, las condiciones locales y la legislación vigente, realizar las inspecciones y el mantenimiento de la grifería a intervalos regulares.

Datos técnicos

- ▶ Presión mínima de flujo 1,0 bar
- ▶ Presión máxima de servicio 10 bares
- ▶ Presión de flujo recomendada 3 bares
- ▶ Flujo volumétrico con 3 bares de presión de flujo 9 l/min
- ▶ Tiempo de flujo a 38 °C 5-35 s, ajustable

IT

Istruzioni per il montaggio e l'uso

Avvertenze importanti

- ▶ Sciacquare le tubazioni prima di installare!
- ▶ A montaggio avvenuto impostare il blocco temperatura.
- ▶ Utilizzare la rubinetteria esclusivamente con i filtri e le valvole antiriflusso originali!
- ▶ Controllare e sottoporre a manutenzione l'apparecchio ad intervalli regolari, in funzione della qualità dell'acqua, delle caratteristiche locali e delle vigenti disposizioni locali.

Specifiche tecniche

- ▶ Pressione idraulica min. 1,0 bar
- ▶ Pressione di esercizio max. 10 bar
- ▶ Pressione idraulica consigliata 3 bar
- ▶ Portata volumetrica a 3 bar di pressione idraulica 9 l/min
- ▶ Durata di flusso a 38 °C 5-35 s, impostabile

FI

Asennus- ja käyttöohje

Tärkeitä ohjeita

- ▶ Huuhtele putkijohdot ennen asennusta!
- ▶ Kun asennus on tehty, säädä lämpötilarajoin.
- ▶ Käytä varusteet vain alkuperäisten sihtien ja takaisinvirtauksen eston kanssa!
- ▶ Hana tulee tarkistaa ja huoltaa säännöllisin väliajoin veden laadusta, paikallisista oloista ja paikalla voimassa olevista määräyksistä riippuen.

Tekniset tiedot

- ▶ Vähimmäisvirtauspaine 1,0 bar
- ▶ Suurin käyttöpaine 10 bar
- ▶ Suositeltava virtauspaine 3 bar
- ▶ Tilavuusvirta 3 barin virtauspaineella 9 l/min
- ▶ Virtausaika 38 °C lämpötilassa 5-35 s, säädettävissä

RU

Инструкция по монтажу и вводу в эксплуатацию

Важные указания

- ▶ Перед инсталляцией промыть трубки!
- ▶ После произведенного монтажа настроить температурный упор.
- ▶ Эксплуатировать арматуру только с оригинальными фильтрами и клапанами обратного течения!
- ▶ Арматуру необходимо регулярно чистить и обслуживать в зависимости от качества воды, местных условий и действующих в месте эксплуатации предписаний.

Технические характеристики

- ▶ Минимальный гидравлический напор 1,0 бар
- ▶ Максимальное рабочее давление 10 бар
- ▶ Рекомендуемый гидравлический напор 3 бар
- ▶ Объёмный расход при гидравлическом напоре 3 бар 9 л/мин
- ▶ Продолжительность истечения при 38 °C 5-35 s, регулируемое

Belangrijke aanwijzingen

- ▶ Voor installatie buisleidingen spoelen!
- ▶ Na de montage de temperatuuurbegrenzing instellen.
- ▶ Armatuur alleen met originele zeven gebruiken!
- ▶ Afhankelijk van de waterkwaliteit, de plaatselijke omstandigheden en de plaatselijke voorschriften de armatuur regelmatig controleren en onderhouden.

Technische gegevens

- ▶ Minimale dynamische druk 1,0 bar
- ▶ Maximale werkdruk 10 bar
- ▶ Aanbevolen dynamische druk 3 bar
- ▶ Volumestroom bij 3 bar dynamische druk 9 l/min
- ▶ Stromingstijd bij 38 °C 5-35 s, instelbaar



1. Montage

EN Installation
FR Montage
ES Montaje
IT Montaggio

NL Montage
PL Montaż
SV Montering

CS Montáž
FI Asennus
RU Монтаж



1

1

2

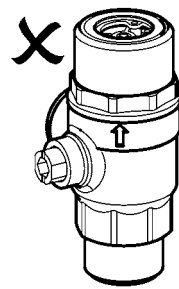
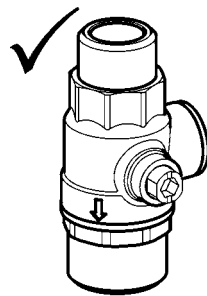
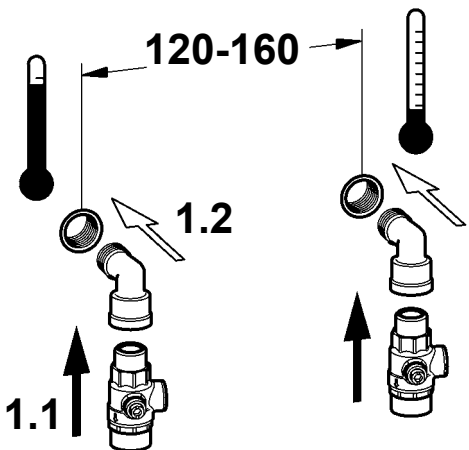
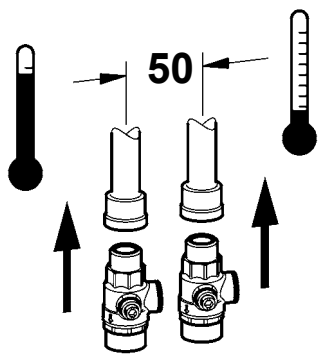

2

2.1

2.2

2.3

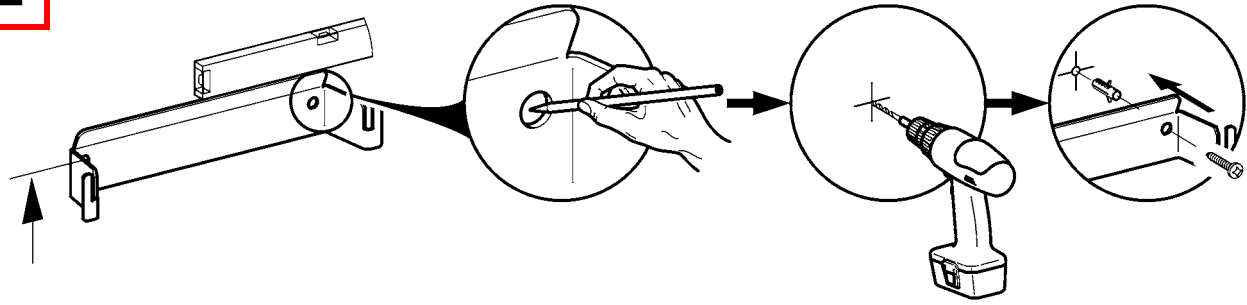

2,14 m - 2,34 m

5

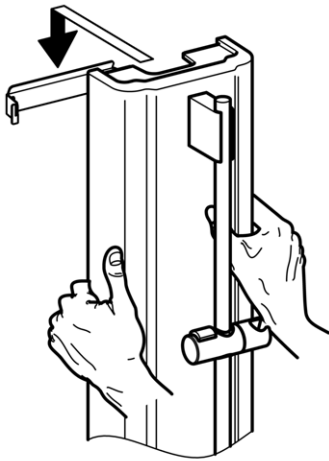

6

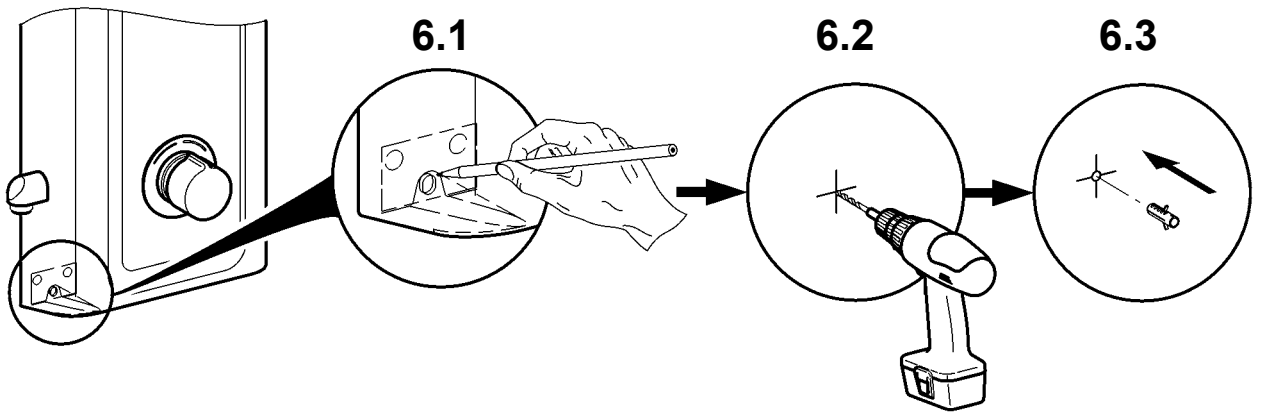

7

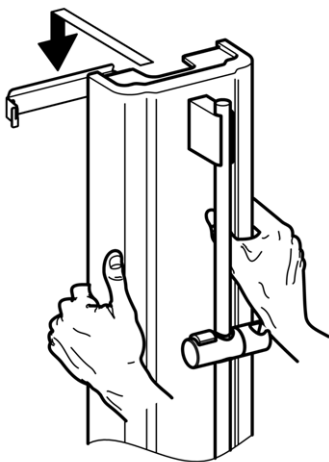

8

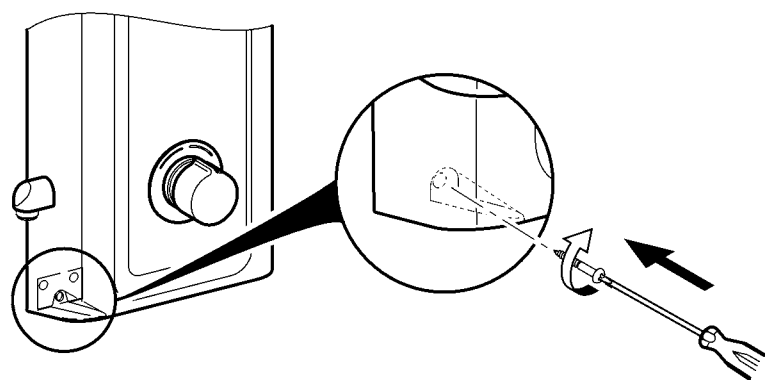

9

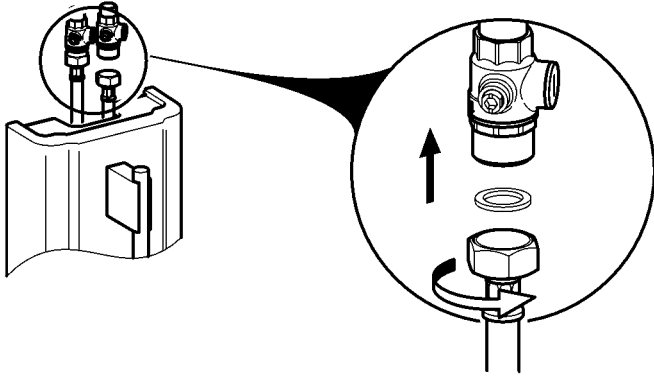

10

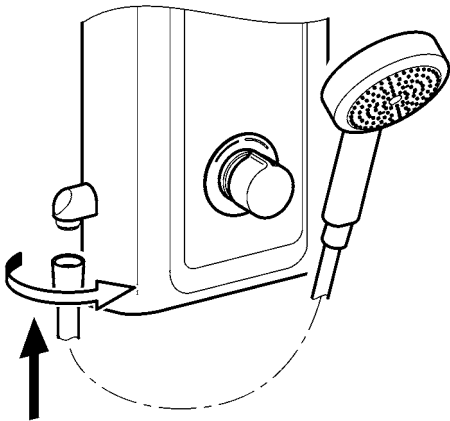

11

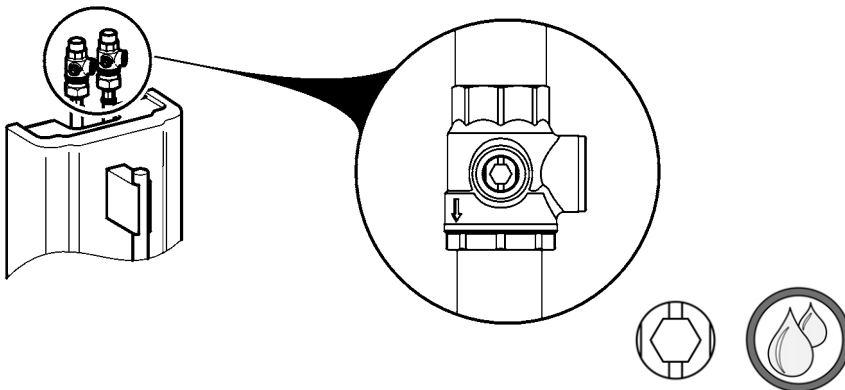

12

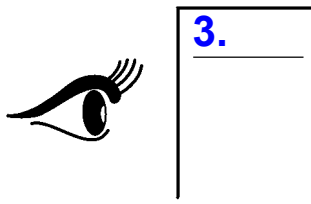

13

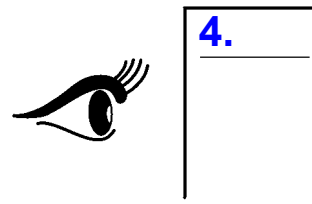

14

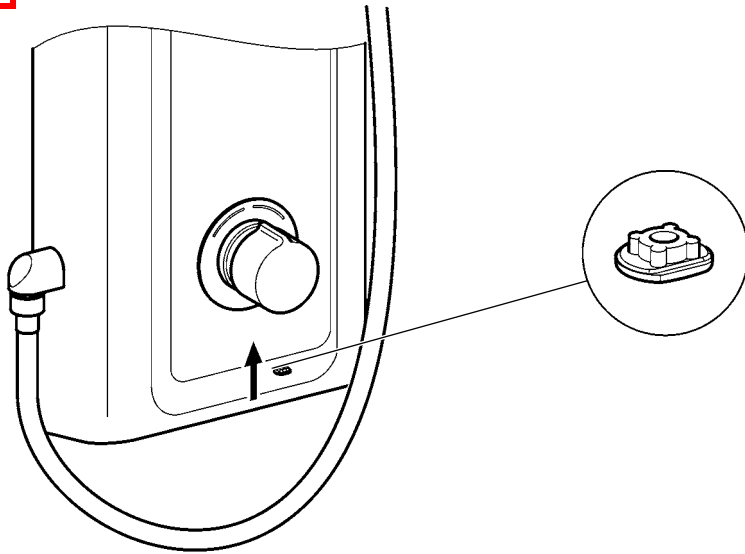

2. Funktion

EN Function
FR Fonctionnement
ES Función
IT Funzionamento

NL Werking
PL Funkcja
SV Funktion

CS Funkce
FI Toiminto
RU Функционирование

1

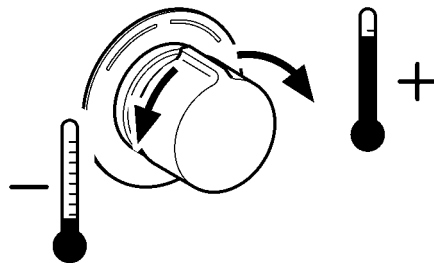
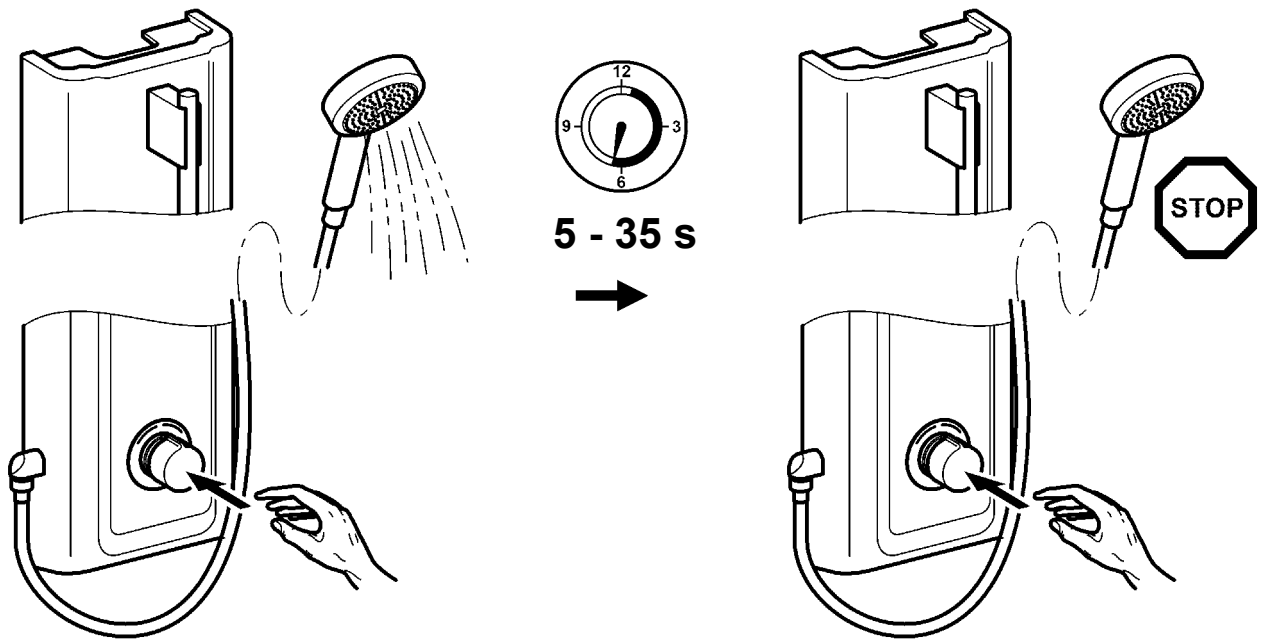

3. Fließzeit einstellen

EN Adjust flow duration

NL Stromingstijd instellen

CS Nastavit dobu průtoku

FR Régler la durée d'écoulement

PL Ustawić czas przepływu

FI Aseta virtausaika

ES Ajustar el tiempo de flujo

SV Ställa in flytförmågan

RU Регулировка времени истечения

IT Impostazione della durata di flusso

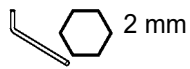

1

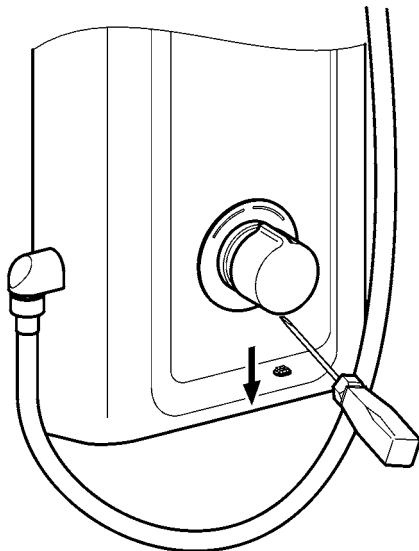

2

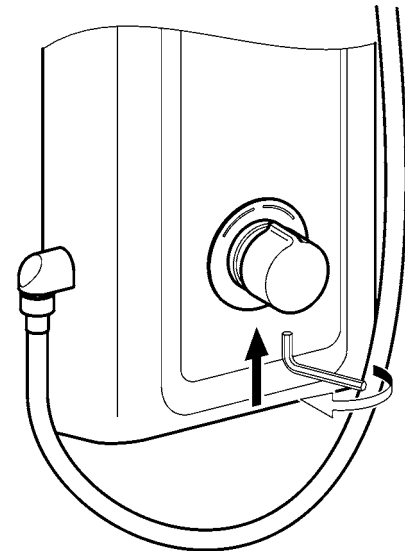

3

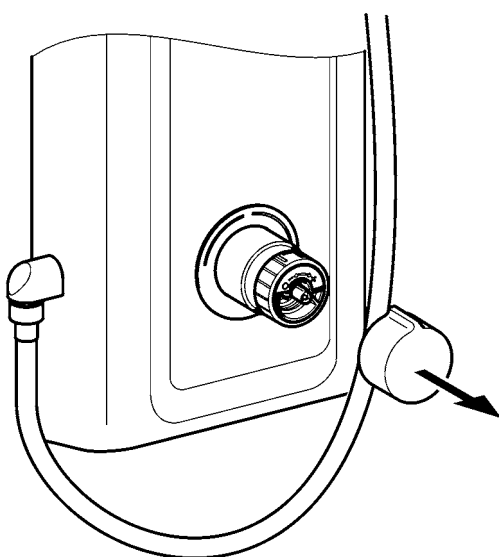

4

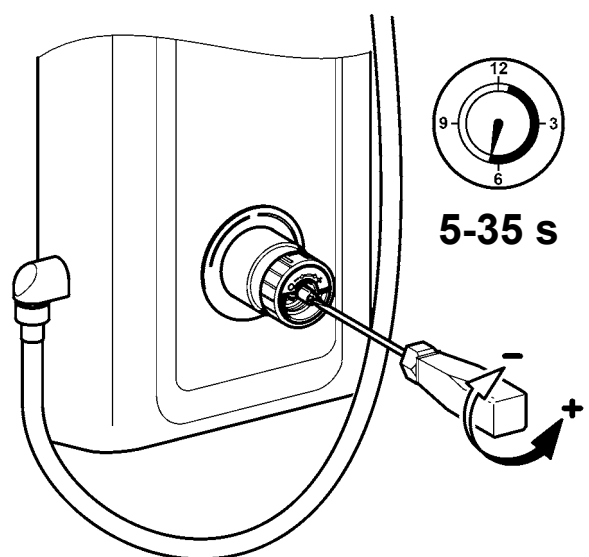

5

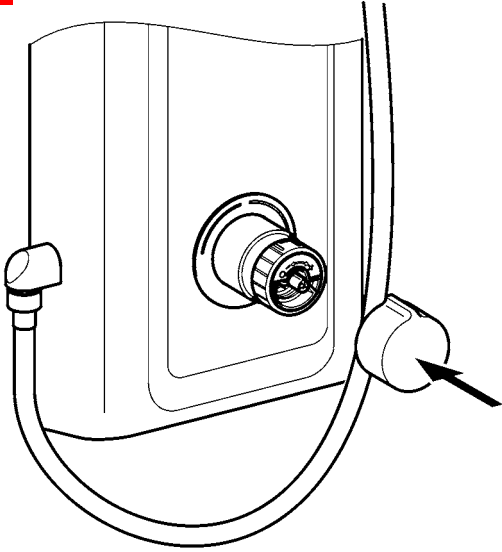

6

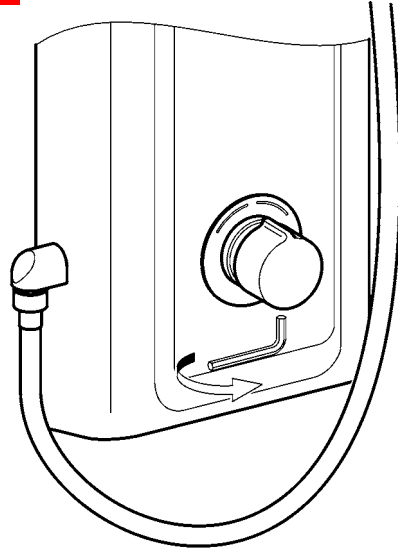

7

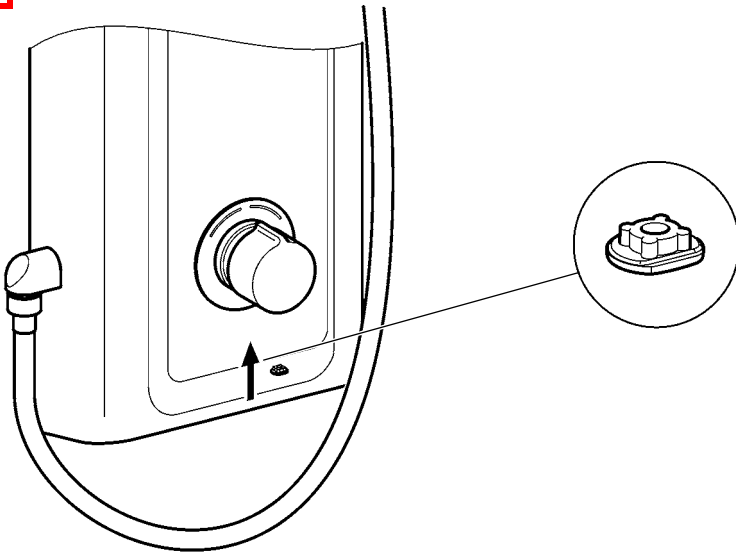

4. Temperaturanschlag einstellen

EN Setting the temperature stop

NL Temperatuurbegrenzing instellen

CS Nastavení teplotního limitu

FR Réglage de la butée de température

PL Ustawienie ograniczenia temperatury

FI Lämpötilarajoittimen säätäminen

ES Ajuste del tope de temperatura

SV Ställa in temperaturstoppet

RU Настройка температурного упора

IT Impostazione del blocco temperatura

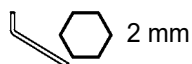

1

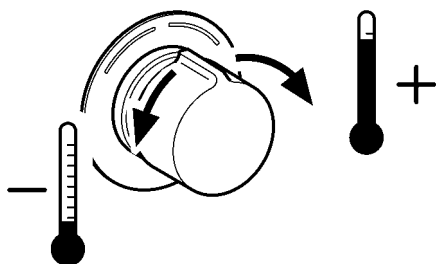

2

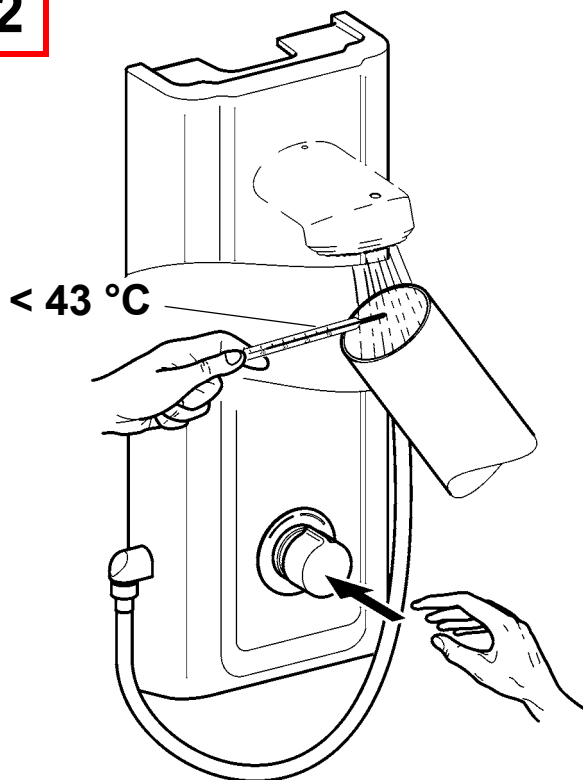

3

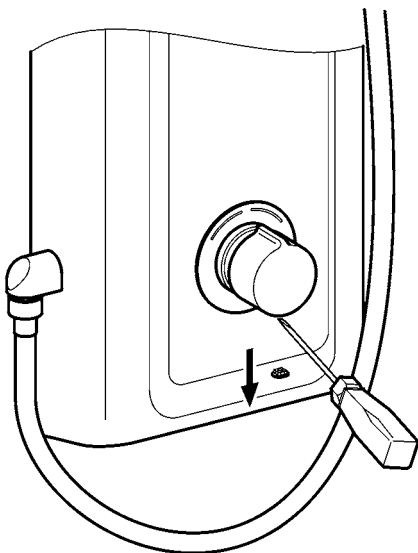

4

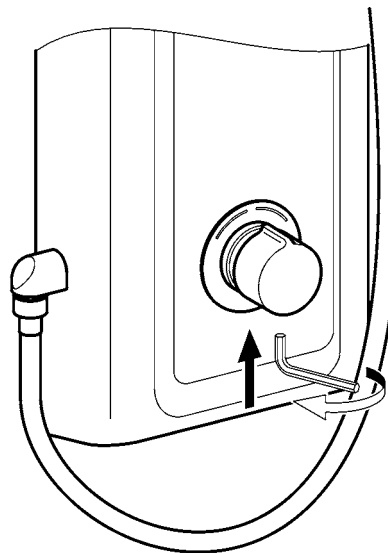

5

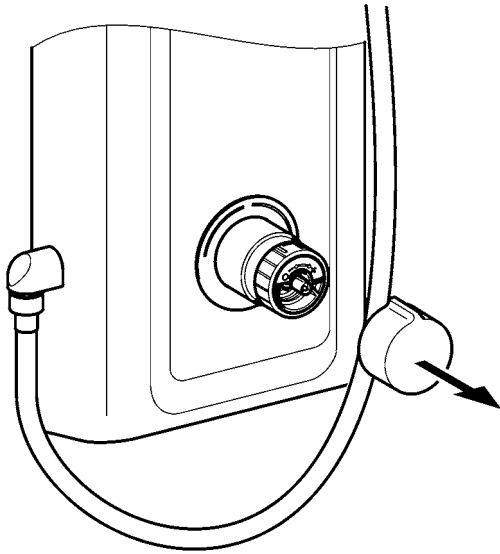

6

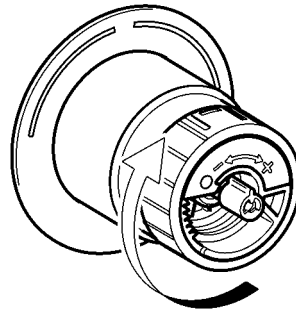

7

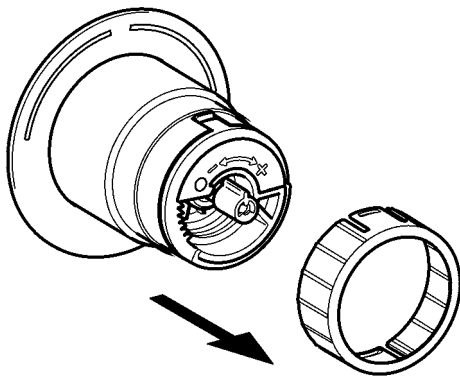

8

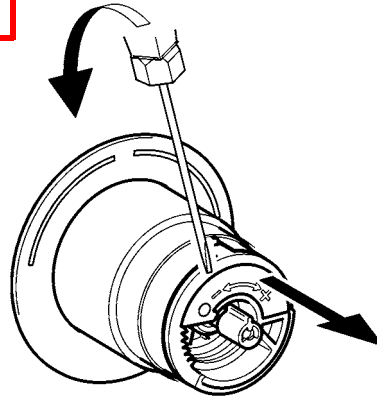

9

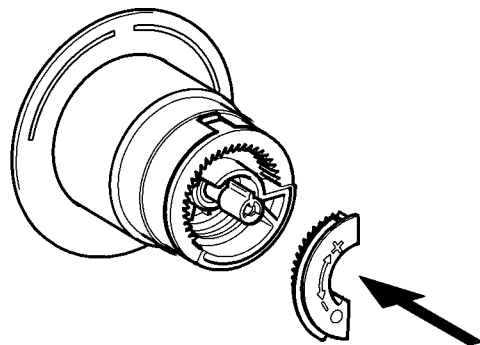
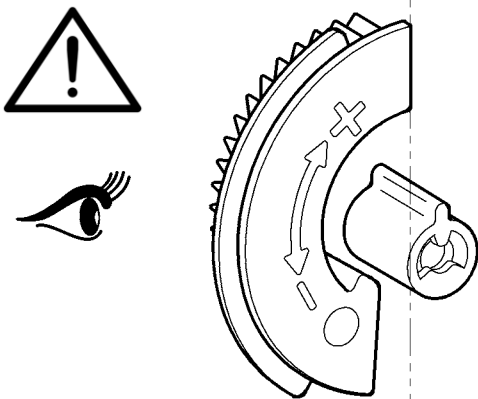

10

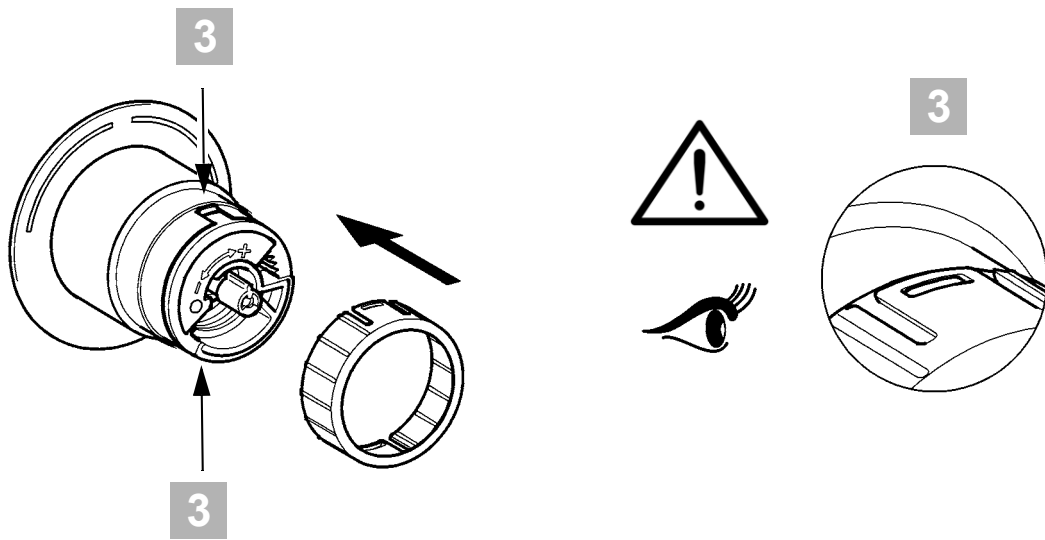

11

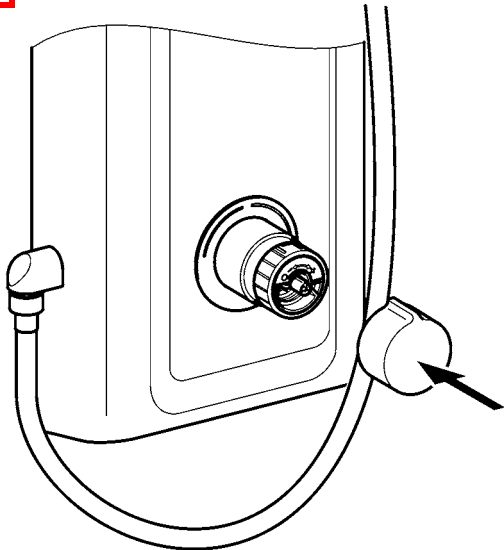

12

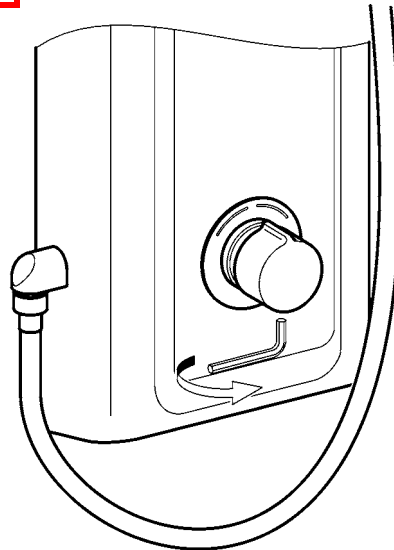

13

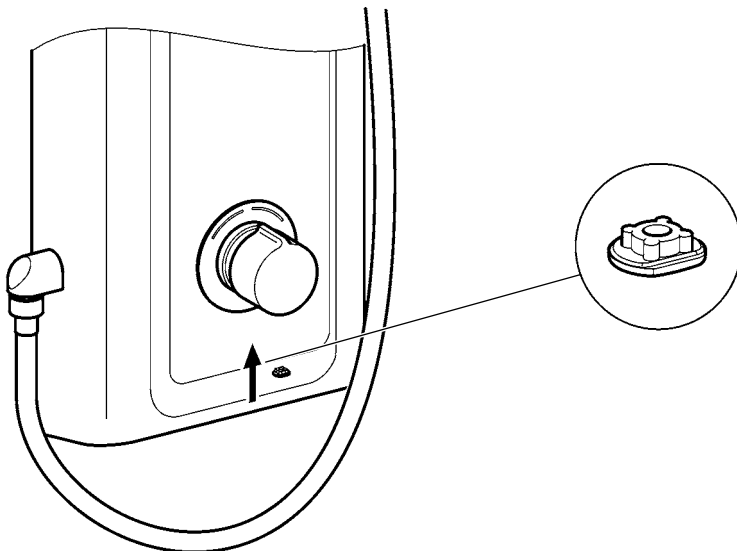

5. Wartung

EN Maintenance
FR Maintenance
ES Mantenimiento
IT Manutenzione

NL Onderhoud
PL Konserwacja
SV Underhåll

CS Varování
FI Huolto
RU Техническое обслуживание



8.

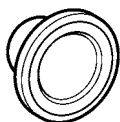

9.

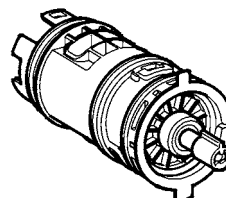

10.

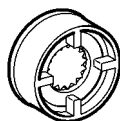

11.

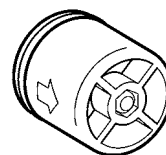

6. Paneel abnehmen

EN Removing the panel

FR Retirer le panneau

ES Retirar el panel

IT Rimozione del pannello

NL Paneel weghalen

PL Zdejnowanie panelu

SV Ta bort panelen

CS Demontujte panel

FI Paneelin irrottaminen

RU Снятие панели

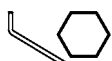

5 mm

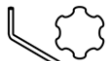

TX 25

1

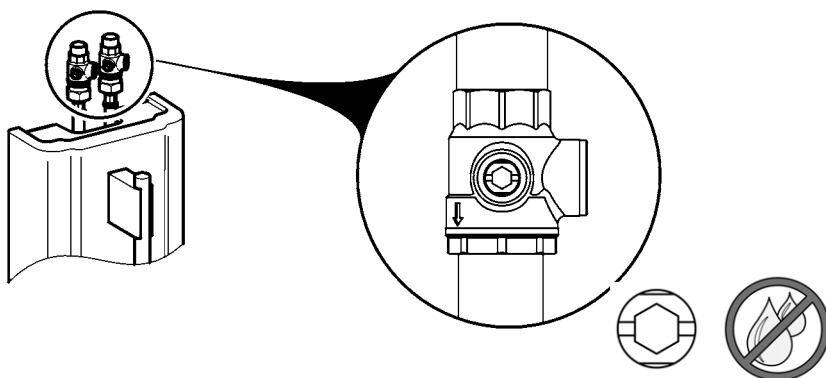

2

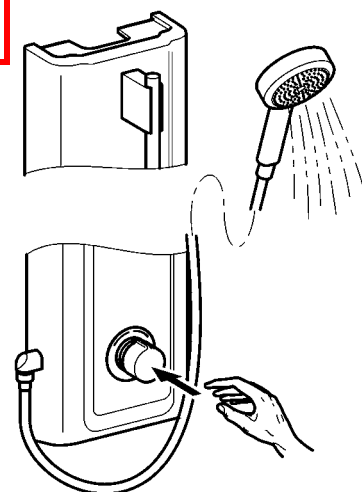

3

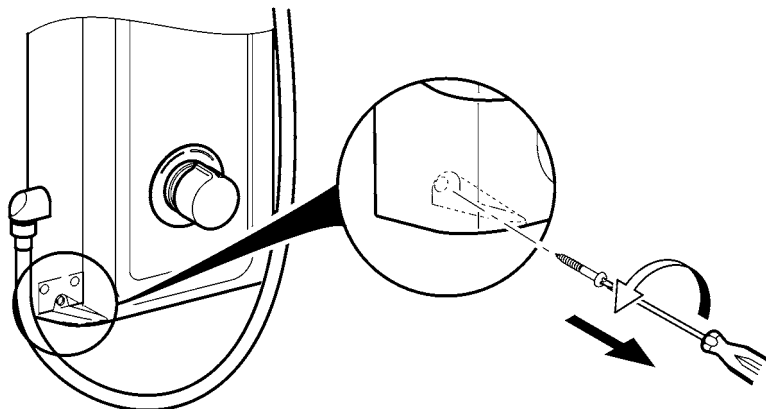

4

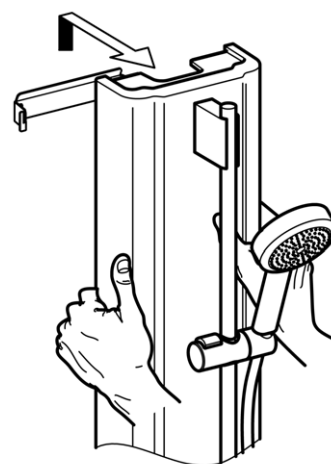

5

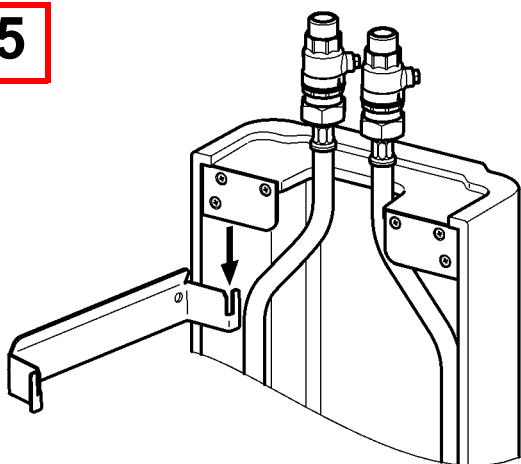

7. Paneel montieren

EN Mounting the panel

FR Monter le panneau

ES Montar el panel

IT Montaggio del pannello

NL Paneel monteren

PL Montaż panelu

SV Montera panelen

CS Namontujte panel

FI Paneelin asentaminen

RU Монтаж панели

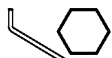

5 mm



TX 25

1

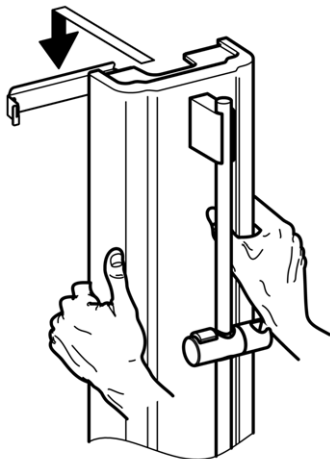

2

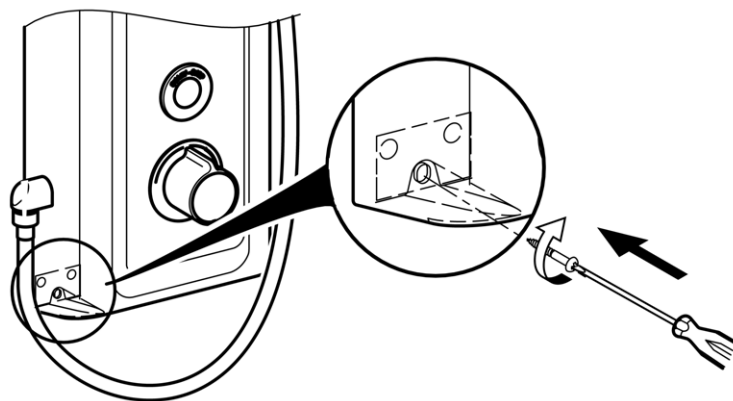

3

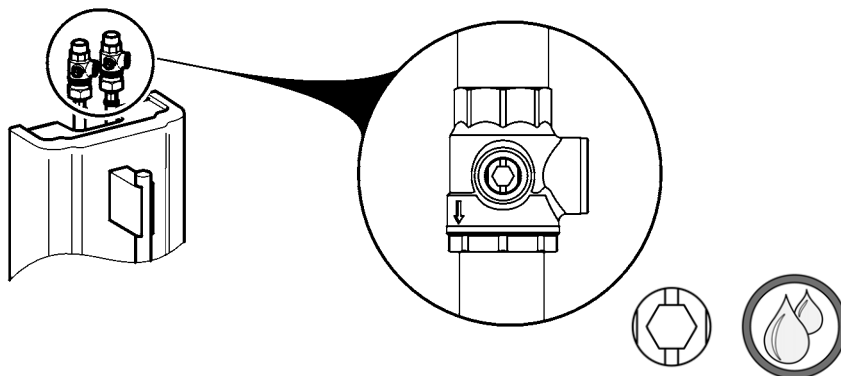

8. Siebe wechseln

EN Replace the filters
FR Remplacement les filtres
ES Cambiar los tamices
IT Sostituire i filtri

NL Zeven vervangen
PL Wymiana sit
SV Byt filter

CS Vyměňte síto
FI Siivilän vaihto
RU Сменить сеточки

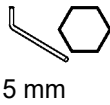

5 mm

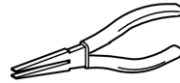

1

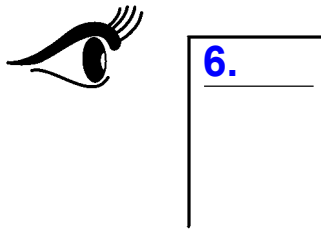

2

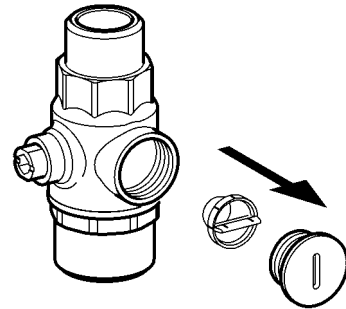

3

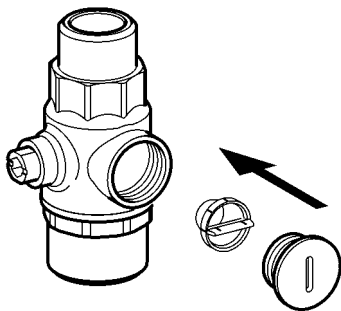

4

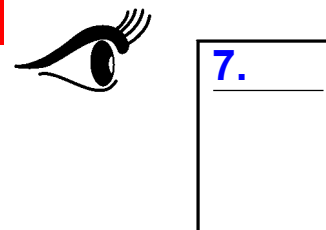

9. Selbstschluss-Kartusche wechseln

EN	Replace self-closing cartridge	PL	Wymienić wkład samozamykający
FR	Remplacement de la cartouche mélangeuse à fermeture automatique	SV	Byta självstängande patron
ES	Cambio de cartucho con cierre automático	CS	Výměna kartuše vodovodní baterie
IT	Sostituzione della cartuccia a chiusura automatica	FI	Itsesulkeutuvan panoksen vaihtaminen
NL	Zelfsluitende patroon vervangen	RU	Замена самоблокирующегося картриджа

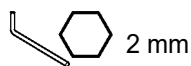

1

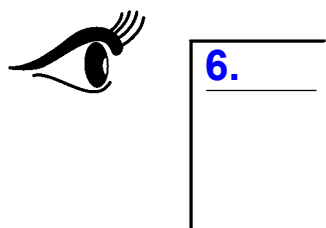

2

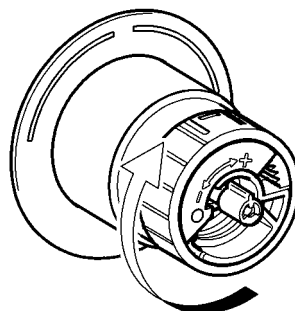

3

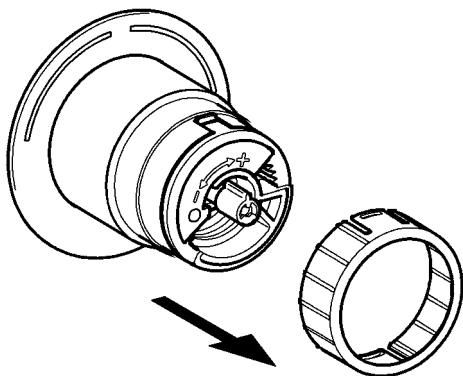

4

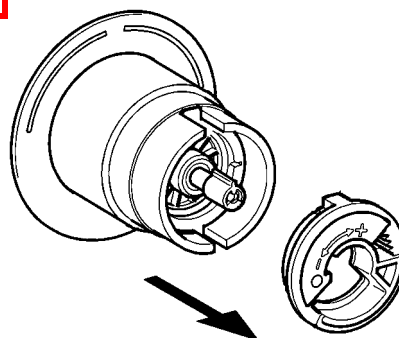

5

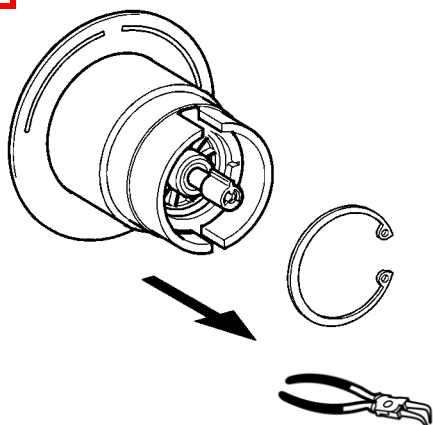

6

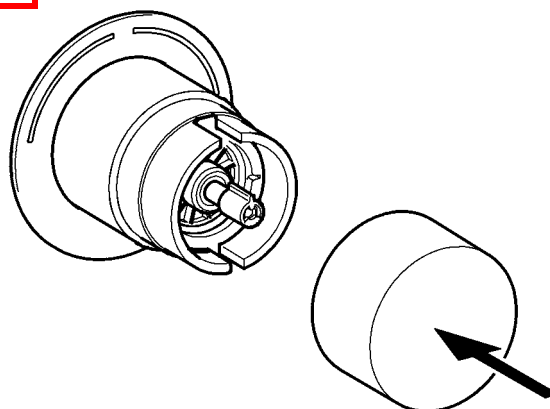

7

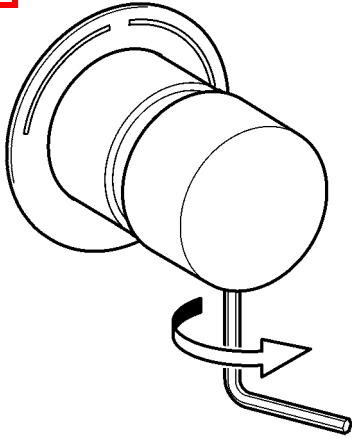

8

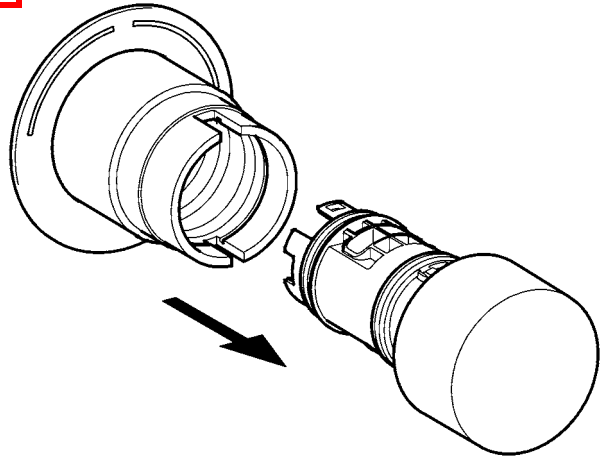

9

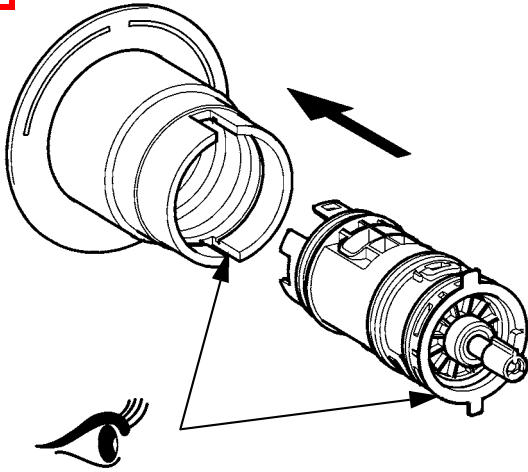

10

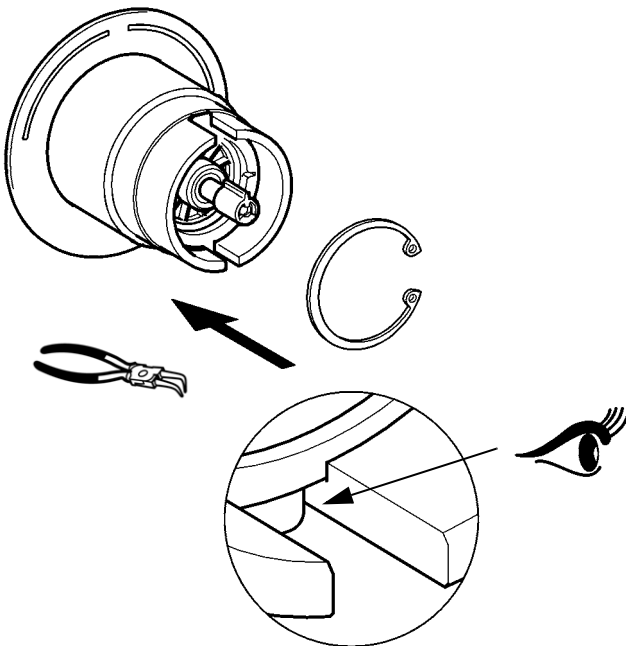

11

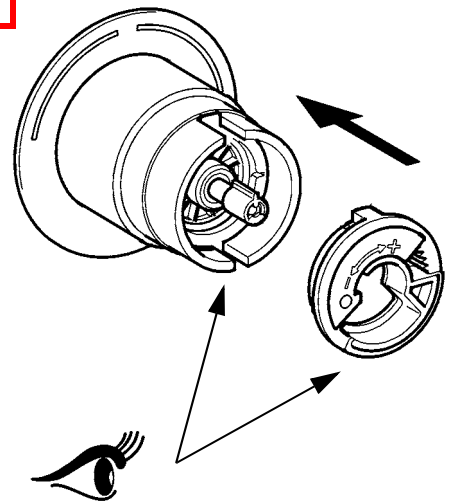

12

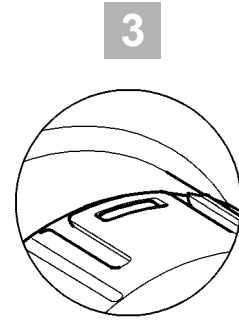
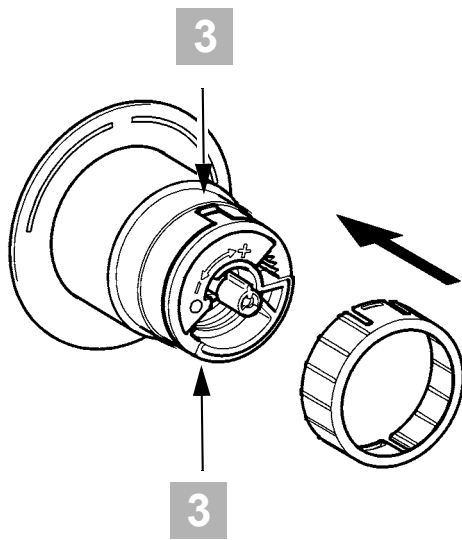

13



3.

14



7.

10. Durchflussmengenregler wechseln

EN Replace the flow rate regulator	NL Debietregelaar vervangen	CS Byt flödesregulator
FR Remplacement du régulateur de débit	PL Wymiana regulatora wielkości przepływu	FI Lämpivirtausmäärän säätimen vaihto
ES Cambiar el regulador volumétrico de paso	SV Byt flödesregulator	RU Заменить регулятор расхода
IT Sostituire il regolatore di portata		

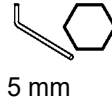
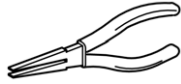

5 mm

1

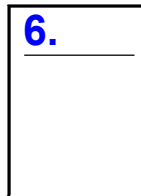

2

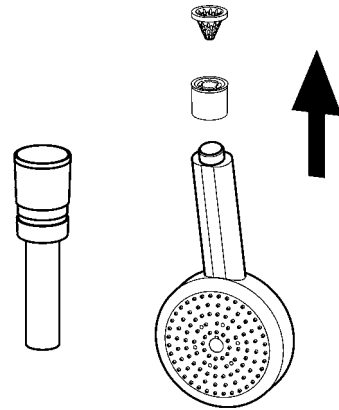

3

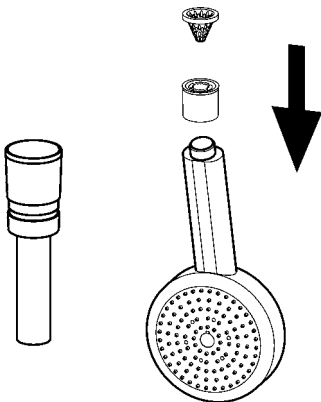

4

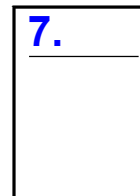

11. Rückflussverhinderer wechseln

EN Replace the return flow inhibitor	NL Terugstroomklep vervangen	CS Vyměňte zábranu zpětného průtoku
FR Remplacement du clapet de non-retour	PL Wymiana zaworu zwrotnego	FI Paluuvirtausestäjän vaihto
ES Reemplazar la válvula antiretorno	SV Byt återströmningsskydd	RU Заменить клапан обратного течения
IT Sostituire la valvola antiriflusso		

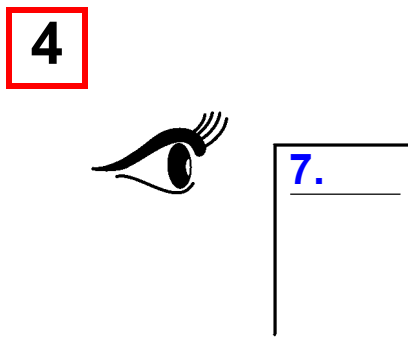
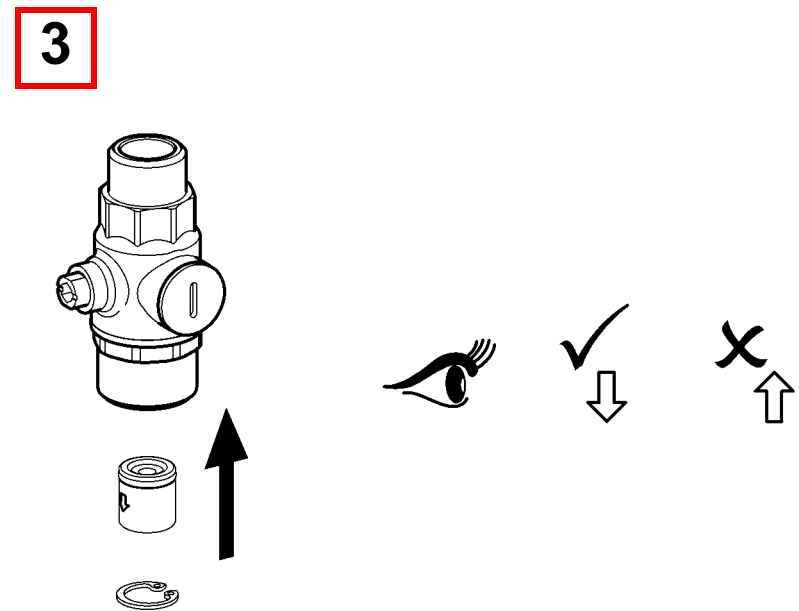
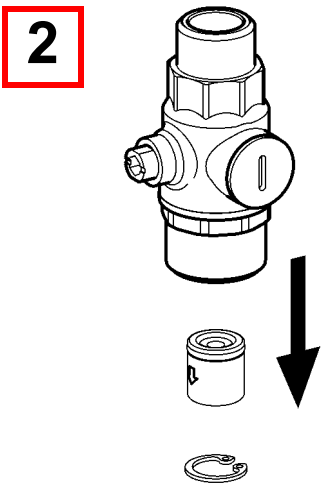
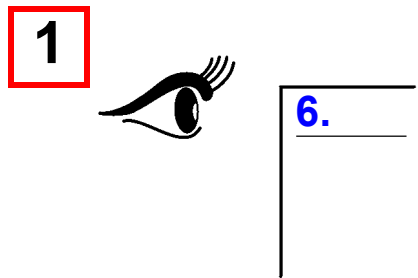

ZMI_001_2030058860_#SALL_#AQU_#V3.fm

12. Ersatzteile I

EN Replacement parts I
FR Pièces de rechange I
ES Piezas de recambio I
IT Pezzi di ricambio I

NL Reserveonderdelen I
PL Części zamienne I
SV Reservdelar I

CS Náhradní díly I
FI Varaosat I
RU Запчасти I

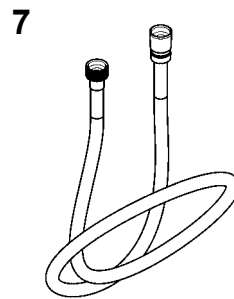
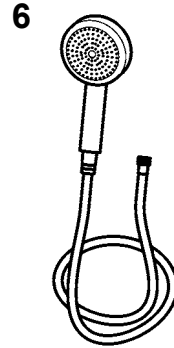
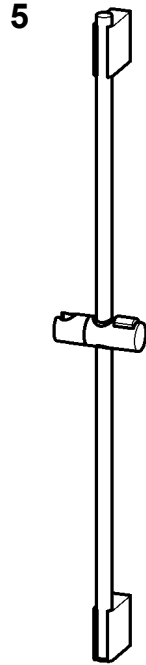
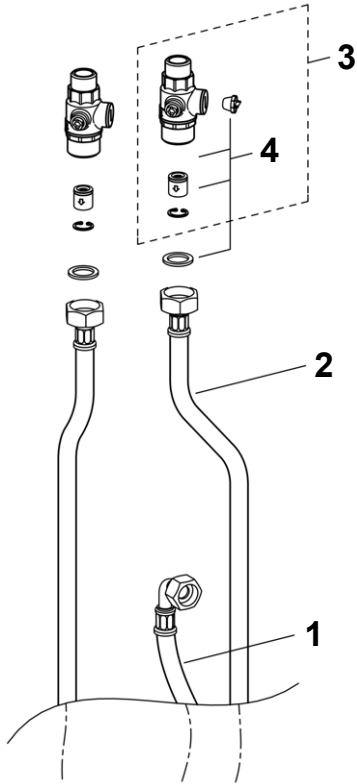

- 1..... 2030062339
ASXX2011
2..... 2030060321
ASXX2007
3..... 2030060314
ASXX2005
4..... 2030060824 a)
ASXX2006
5..... 2030062340
ASXX2012
6..... 2030051216
ACXX2007
7..... 2030051574
ASXX2001
8..... 2030051583 b)
ASXX2003

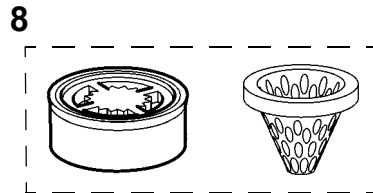

EN a) 2 pieces
b) 5 pieces

ES a) 2 piezas
b) 5 piezas

PL a) 2 sztuk
b) 5 sztuk

FI a) 2 kappaletta
5 kappaletta

DE a) 2 Stück
b) 5 Stück

IT a) 2 pezzi
b) 5 pezzi

SV a) 2 styck
b) 5 styck

RU a) 2 штук
5 штук

FR a) 2 pièces
b) 5 pièces

NL a) 2 stuk
b) 5 stuk

CS a) 2 kusů
b) 5 kusů

13. Ersatzteile II

EN Replacement parts II
FR Pièces de rechange II
ES Piezas de recambio II
IT Pezzi di ricambio II

NL Reserveonderdelen II
PL Części zamienne II
SV Reservdelar II

CS Náhradní díly II
FI Varaosat II
RU Запчасти II

9..... 2030053006 ^{b)} ASSX9004	14 .. 2030045510 ASXM2003
10... 2030050753 ASSM9004	15 .. 2030046185 ASSM9001
11... 2030048356 ASSX9002	16 .. 2030062702 ASSM2005
12... 2030046189 ASSM9002	
13... 2030048357 ^{a)} ASSX9003	

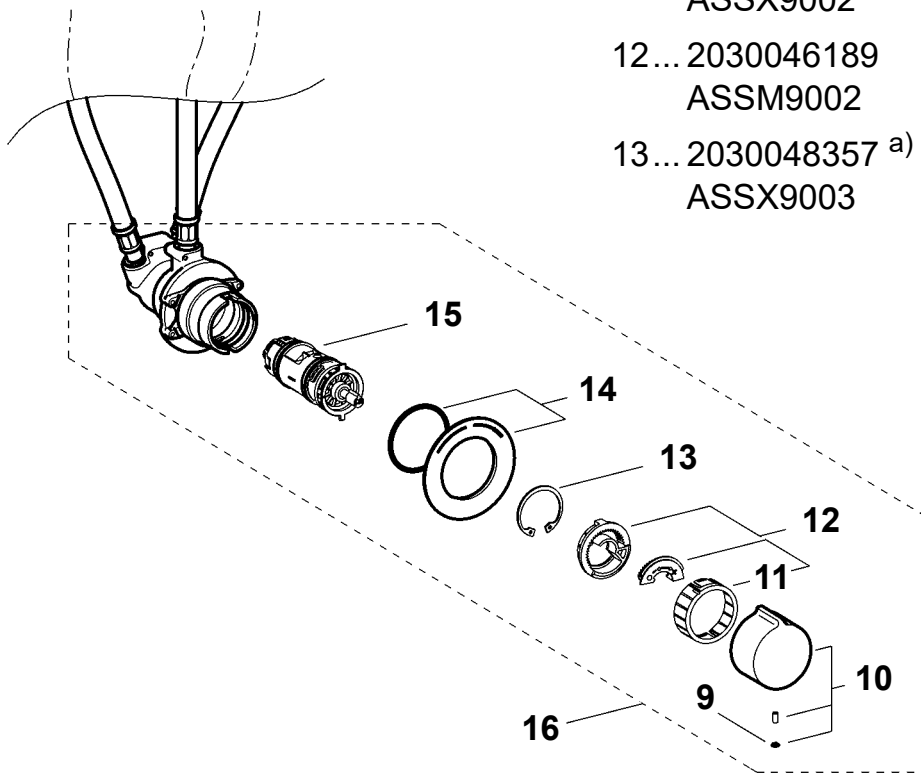

EN a) 5 pieces b) 10 pieces	ES a) 5 piezas b) 10 piezas	PL a) 5 sztuk b) 10 sztuk	FI a) 5 kappaletta b) 10 kappaletta
DE a) 5 Stück b) 10 Stück	IT a) 5 pezzi b) 10 pezzi	SV a) 5 styck b) 10 styck	RU a) 5 штук b) 10 штук
FR a) 5 pièces b) 10 pièces	NL a) 5 stuk b) 10 stuk	CS a) 5 kusů b) 10 kusů	

14. Zubehör

EN Accessories
FR Accessoire
ES Accesorios
IT Accessori

NL Toebehoren
PL Akcesoria
SV Tillbehör

CS Příslušenství
FI Lisävarusteet
RU принадлежности

1

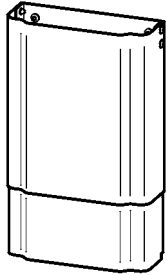

2

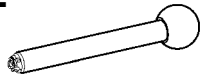

1..... **110-170 mm:**

2030057071

ACXX2016

160-250 mm:

2030057072

ACXX2017

240-410 mm:

2030057073

ACXX2018

400-660 mm:

2030057075

ACXX2019

650-960 mm:

2030057076

ACXX2020

2..... 2030047203

ACXX9003

Notizen

EN Notes

FR Notes

ES Notas

IT Annotazioni

NL Notities

PL Uwagi

SV Notiser

CS Poznámky

FI Muistiinpanot

RU Примечания

Notizen

EN Notes

FR Notes

ES Notas

IT Annotazioni

NL Notities

PL Uwagi

SV Notiser

CS Poznámky

FI Muistiinpanot

RU Примечания

Notizen

EN Notes

FR Notes

ES Notas

IT Annotazioni

NL Notities

PL Uwagi

SV Notiser

CS Poznámky

FI Muistiinpanot

RU Примечания

Australia

PR Kitchen and
Water Systems Pty Ltd
Dandenong South VIC 3175
Phone +61 3 9700 9100

Austria

KWC Austria GmbH
6971 Hard, Austria
Phone +43 5574 6735 0

**Belgium, Netherlands &
Luxembourg**

KWC Aquarotter GmbH
9320 Aalst; Belgium
Phone +31 (0) 492 728 224

Czech Republic

KWC Aquarotter GmbH
14974 Ludwigsfelde, Germany
Phone +49 3378 818 309

France

KWC Austria GmbH
6971 Hard, Austria
Phone +33 800 909 216

Germany

KWC Aquarotter GmbH
14974 Ludwigsfelde
Phone +49 3378 818 0

Italy

KWC Austria GmbH
6971 Hard, Austria
Numero Verde +39 800 789 233

Middle East

KWC ME LLC Ras Al Khaimah,
United Arab Emirates
Phone +971 7 2034 700

Poland

KWC Aquarotter GmbH
14974 Ludwigsfelde, Germany
Phone +48 58 35 19 700

Spain

KWC Austria GmbH
6971 Hard, Austria
Phone +43 5574 6735 211

Switzerland & Liechtenstein

KWC Group AG
5726 Unterkulm, Switzerland
Phone +41 62 768 69 00

Turkey

KWC ME LLC Ras Al Khaimah,
United Arab Emirates
Phone +971 7 2034 700

United Kingdom

KWC DVS Ltd - Northern Office
Barlborough S43 4PZ
Phone +44 1246 450 255

KWC DVS Ltd - Southern Office
Paignton TQ4 7TW
Phone +44 1803 529 021

EAST EUROPE

Bosnia Herzegovina
Bulgaria | Croatia
Hungary | Latvia
Lithuania | Romania
Russia | Serbia | Slovakia
Slovenia | Ukraine

KWC Aquarotter GmbH
14974 Ludwigsfelde, Germany
Phone +49 3378 818 261

SCANDINAVIA & ESTONIA

Finland | Sweden | Norway
Denmark | Estonia

KWC Nordics Oy
76850 Naarajärvi, Finland
Phone +358 15 34 111

OTHER COUNTRIES

KWC Austria GmbH
6971 Hard, Austria
Phone +43 5574 6735 0

