

F5

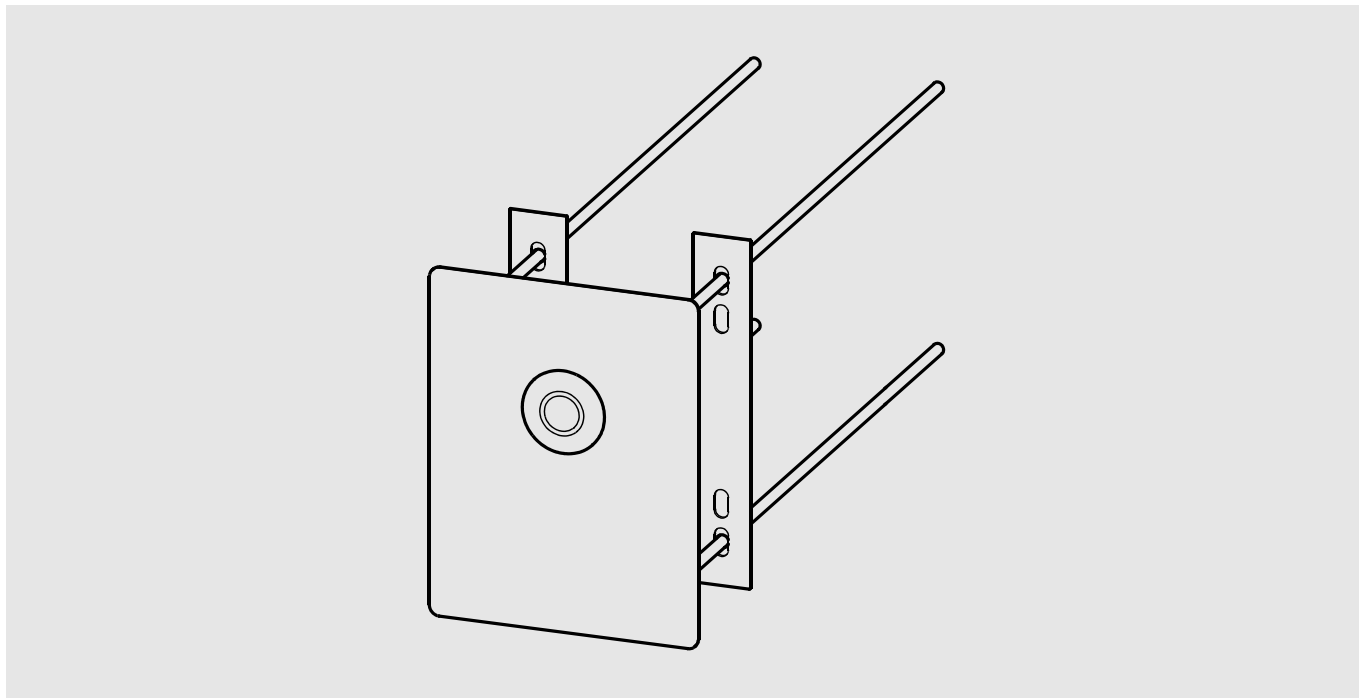

F5EF4003
2030068176

DE	Montage- und Betriebsanleitung	WC-Spülarmatur
EN	Installation and operating instructions	WC flush valve
FR	Notice de montage et de mise en service	Robinet de chasse
ES	Instrucciones de montaje y servicio	Válvula de descarga de inodoro
IT	Istruzioni per il montaggio e l'uso	Flussometro WC
NL	Montage- en bedrijfsinstructies	WC-spoelarmatuur
PL	Instrukcja montażu i obsługi	Armatura spłukująca do WC
SV	Monterings- och driftinstruktion	
CS	Návod pro montáž a provoz	Splachovací WC armatura
FI	Asennus- ja käyttöohje	WC huuhteluventtiili
RU	Инструкция по монтажу и вводу в эксплуатацию	

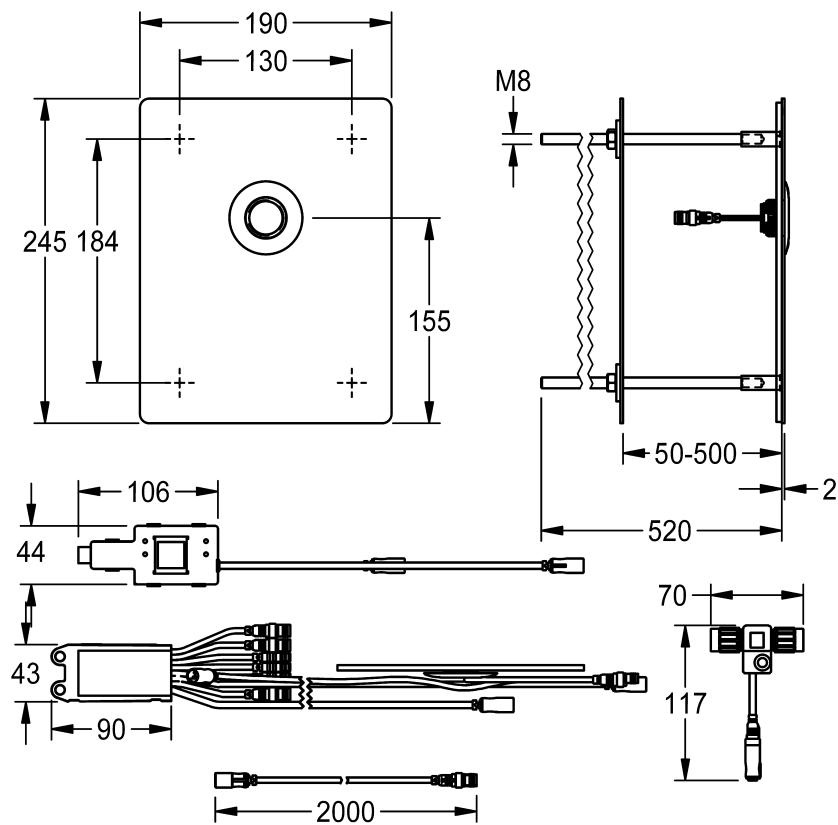
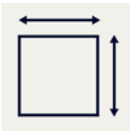
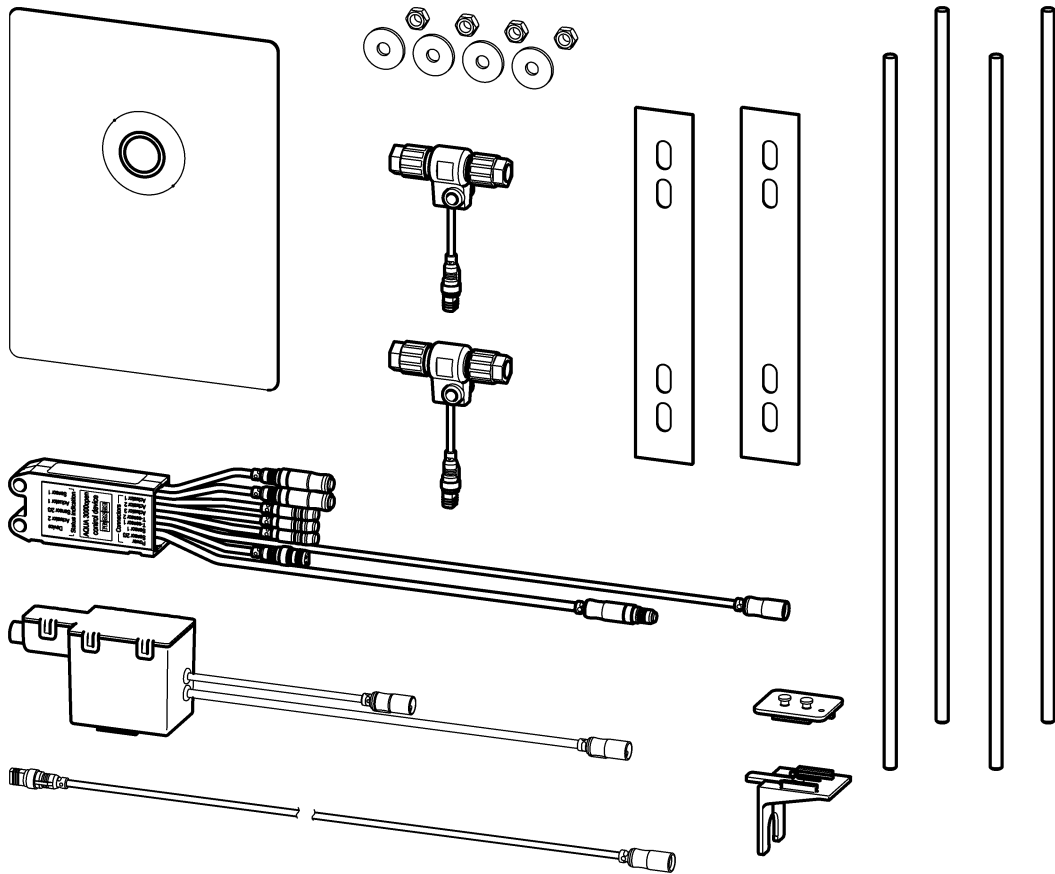

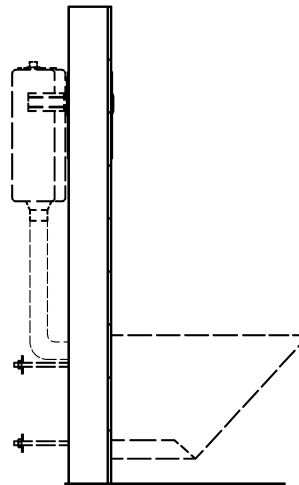
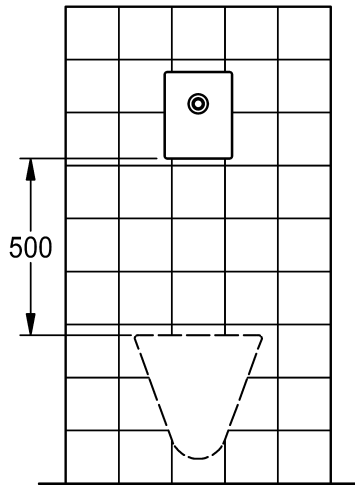
**EN**

Installation and operating instructions

Important notes

- ▶ All work must be carried out in a de-energised state.
- ▶ Before installing flush piping system!
- ▶ The fitting must be operated only with original mesh filters!
- ▶ The fitting must be checked and maintained at regular intervals depending on the water quality and in accordance with the local conditions, and rules and regulations applicable at the site.

Technical data

- ▶ Supply voltage 24 V DC
- ▶ Power consumption 4 W
- ▶ Type of protection IP59k

PL

Instrukcja montażu i obsługi

Ważne wskazówki

- ▶ Wszystkie prace przeprowadzać po odłączeniu zasilania elektrycznego.
- ▶ Przed instalacją przepłukać rury!
- ▶ Armatury należy używać wyłącznie z oryginalnymi siatkami!!
- ▶ Armaturę należy poddawać regularnej kontroli i konserwacji w zależności od jakości wody, warunków lokalnych i obowiązujących przepisów.

DE

Montage- und Betriebsanleitung

Wichtige Hinweise

- ▶ Alle Arbeiten im spannungsfreien Zustand durchführen
- ▶ Vor Installation Rohrleitungen spülen!
- ▶ Armatur nur mit original Sieb betreiben!
- ▶ In Abhängigkeit von der Wasserqualität, den örtlichen Gegebenheiten und den vor Ort geltenden Bestimmungen die Armatur in regelmäßigen Abständen prüfen und warten.

Technische Daten

- ▶ Anschlussspannung 24 V DC
- ▶ Leistungsaufnahme 4 W
- ▶ Schutzart IP59k

SV

Monterings- och driftinstruktion

Viktiga informationer

- ▶ Genomför alla arbeten i spänningslöst tillstånd.
- ▶ Spola igenom rörledningarna före installation!
- ▶ Använd armaturen endast med originalsilar!
- ▶ Kontrollera och serva armaturen med intervaller som bestäms av vattenkvaliteten samt de lokala förhållandena och de bestämmelser som gäller där.

Dane techniczne

- ▶ Napięcie przyłączeniowe 24 V DC
- ▶ Pobór mocy 4 W
- ▶ Rodzaj ochrony IP59k

FR

Notice de montage et de mise en service

Remarques importantes

- ▶ Effectuez tous les travaux quand le dispositif est hors tension.
- ▶ Rincer les conduites avant d'installer !
- ▶ Ne faire fonctionner la robinetterie qu'avec les filtres d'origine !
- ▶ En fonction de la qualité de l'eau, ainsi que des conditions et des dispositions locales, il convient de contrôler et d'entretenir la robinetterie à intervalles réguliers.

Données techniques

- ▶ Tension de raccordement 24 V DC
- ▶ Puissance absorbée 4 W
- ▶ Type de protection IP59k

ES

Instrucciones de montaje y servicio

Indicaciones importantes

- ▶ Todos los trabajos deben realizarse con la tensión de alimentación desconectada.
- ▶ ¡Enjuagar las tuberías antes de instalar!
- ▶ ¡La grifería debe hacerse funcionar únicamente con los tamices originales!
- ▶ En función de la calidad del agua, las condiciones locales y la legislación vigente, realizar las inspecciones y el mantenimiento de la grifería a intervalos regulares.

Datos técnicos

- ▶ Tensión de conexión 24 V DC
- ▶ Consumo de potencia 4 W
- ▶ Modo de protección IP59k

Tekniska data

- ▶ Anslutningsspänning 24 V DC
- ▶ Effektbehov 4 W
- ▶ Skyddsklass IP59k

CS

Návod pro montáž a provoz

Důležité pokyny

- ▶ Veškeré práce vykonávejte ve stavu bez napětí.
- ▶ Před instalací potrubí propláchněte!
- ▶ Provozovat armaturu jen s originálními sítky!
- ▶ V závislosti na kvalitě vody, místních podmínkách a předpisech platných v místě instalace je nutné provádět v pravidelných intervalech kontrolu a údržbu armatury.

Technické údaje

- ▶ Přípojné napětí 24 V DC
- ▶ Příkon 4 W
- ▶ Krytí IP59k



FI

Asennus- ja käyttöohje

Tärkeitä ohjeita

- ▶ Kaikki työt on tehtävä jännitteettömälle järjestelmälle.
- ▶ Huuhtele putkijohdot ennen asennusta!
- ▶ Käytä varusteet vain alkuperäisten sihtien!
- ▶ Hana tulee tarkistaa ja huoltaa säännöllisin väliajoin veden laadusta, paikallisista oloista ja paikalla voimassa olevista määräyksistä riippuen.

Tekniset tiedot

- ▶ Verkkajännite 24 V DC
- ▶ Tehonkulutus 4 W
- ▶ Suojaustapa IP59k

IT Istruzioni per il montaggio e l'uso

Avvertenze importanti

- ▶ Eseguire tutti i lavori fuori tensione.
- ▶ Sciacquare le tubazioni prima di installare!
- ▶ Utilizzare la rubinetteria esclusivamente con i filtri originali!
- ▶ Controllare e sottoporre a manutenzione l'apparecchio ad intervalli regolari, in funzione della qualità dell'acqua, delle caratteristiche locali e delle vigenti disposizioni locali.

Specifiche tecniche

- ▶ Tensione di allacciamento 24 V DC
- ▶ Potenza assorbita 4 W
- ▶ Tipo di protezione IP59k

NL Montage- en bedrijfsinstructies

Belangrijke aanwijzingen

- ▶ Alle werkzaamheden in spanningsloze toestand uitvoeren.
- ▶ Voor installatie buisleidingen spoelen!
- ▶ Armatuur alleen met originele zeven gebruiken!
- ▶ Afhankelijk van de waterkwaliteit, de plaatselijke omstandigheden en de plaatselijke voorschriften de armatuur regelmatig controleren en onderhouden.

Technische gegevens

- ▶ Aansluitspanning 24 V DC
- ▶ Opgenomen vermogen 4 W
- ▶ Veiligheidsgraad IP59k

RU Инструкция по монтажу и вводу в эксплуатацию

Важные указания

- ▶ Выполняйте все работы при отключенном напряжении.
- ▶ Перед инсталляцией промыть трубки!
- ▶ Эксплуатировать арматуру только с оригинальными фильтрами!
- ▶ Арматуру необходимо регулярно чистить и обслуживать в зависимости от качества воды, местных условий и действующих в месте эксплуатации предписаний.

Технические характеристики

- ▶ Напряжение питающей сети 24 В постоянного тока
- ▶ Потребляемая мощность 4 Вт
- ▶ Вид защиты IP59k

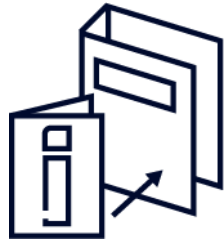
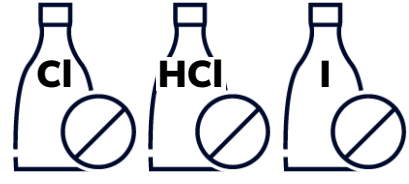

1. Montage

EN Installation
FR Montage
ES Montaje
IT Montaggio

NL Montage
PL Montaż
SV Montering

CS Montáž
FI Asennus
RU Монтаж



32 mm

36 mm

30 mm

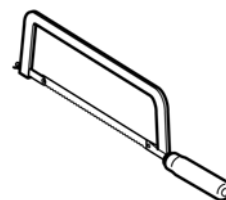

1

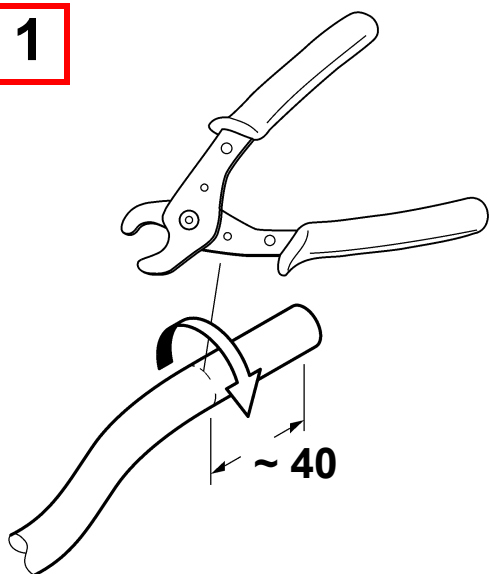

X

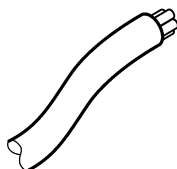

X

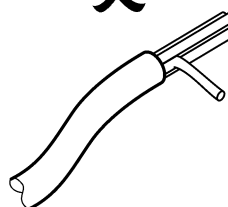

X

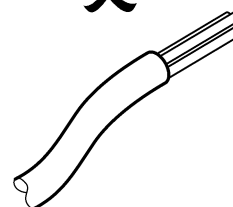

✓

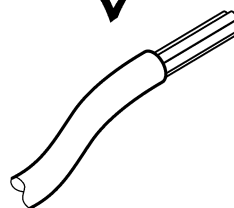

2

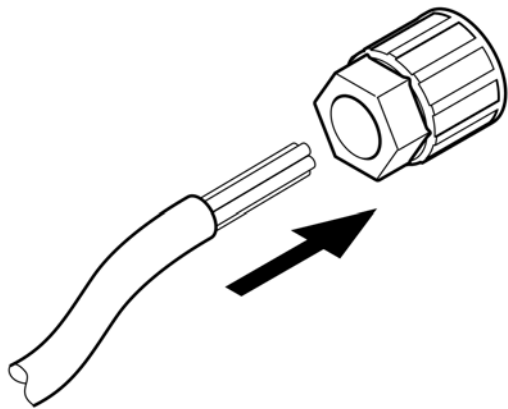

3

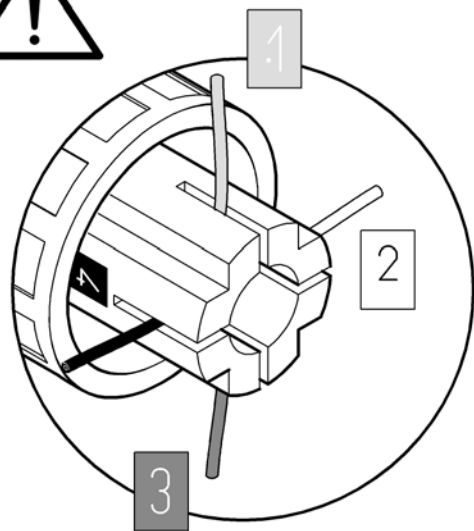
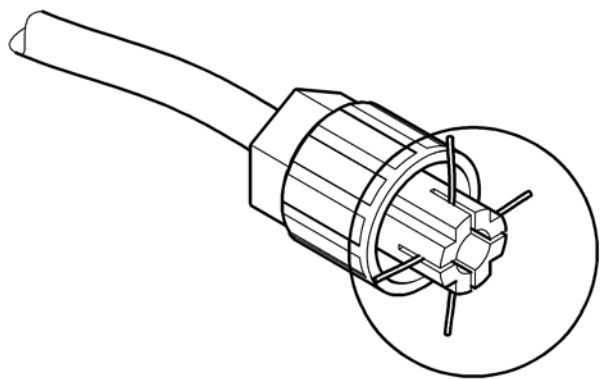

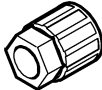
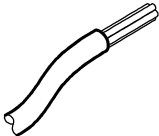
		
1	brown	red
2	white	white
3	blue	blue
4	black	black

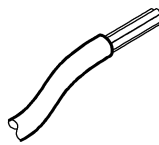

9.

4

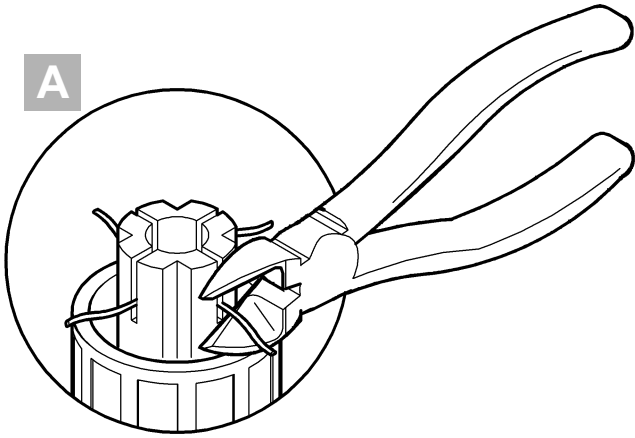
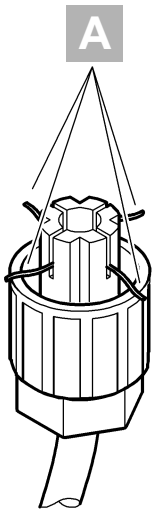

5

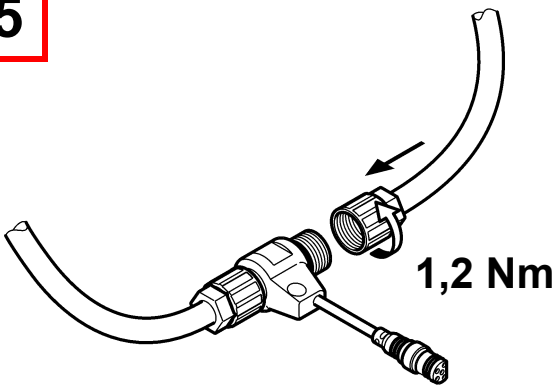

6

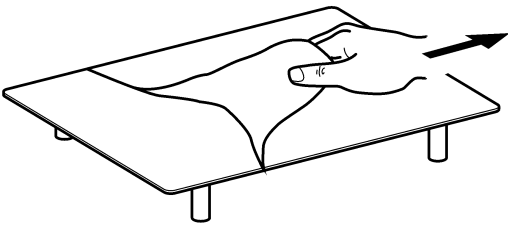

7

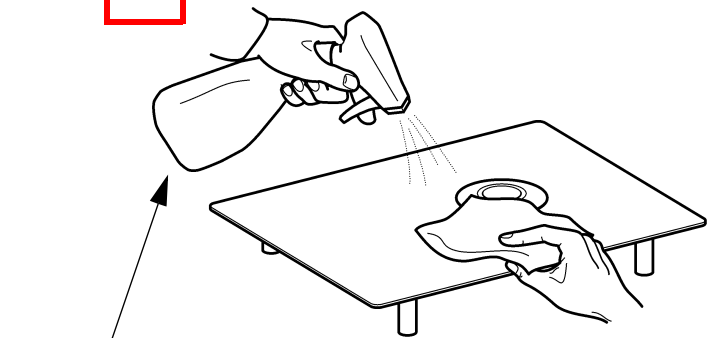

9.

8

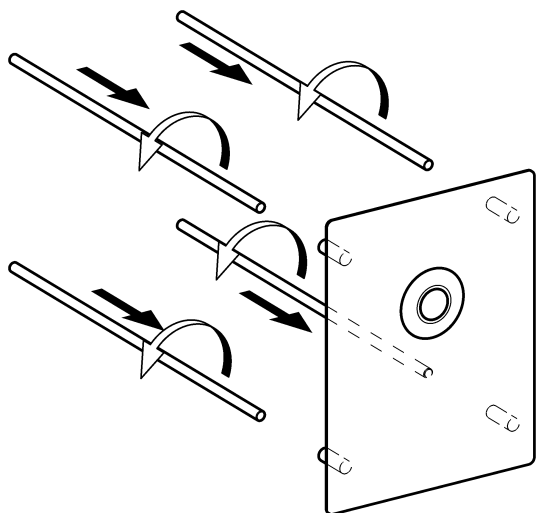

9

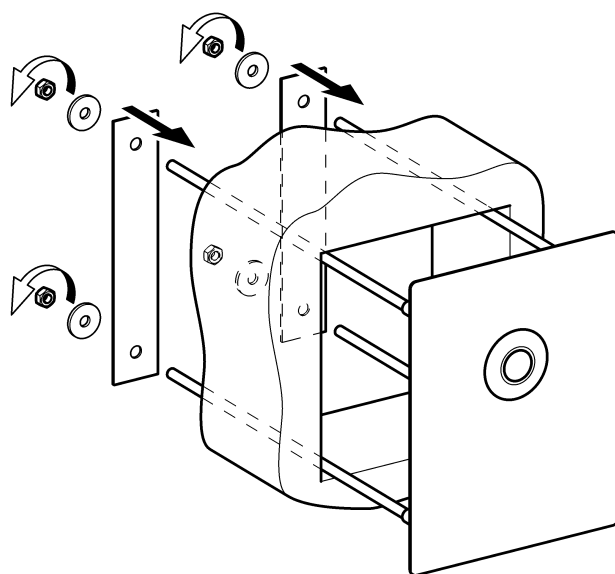

10

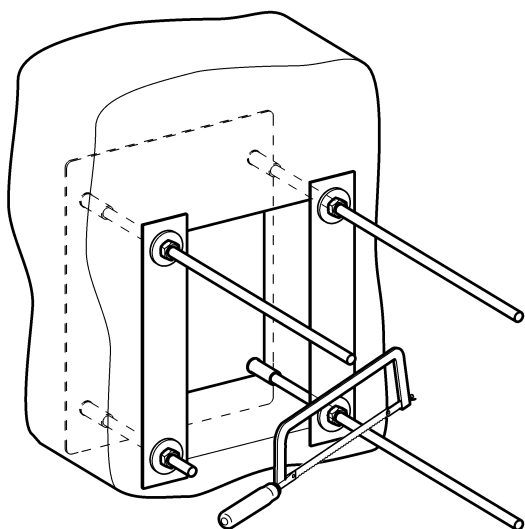

11

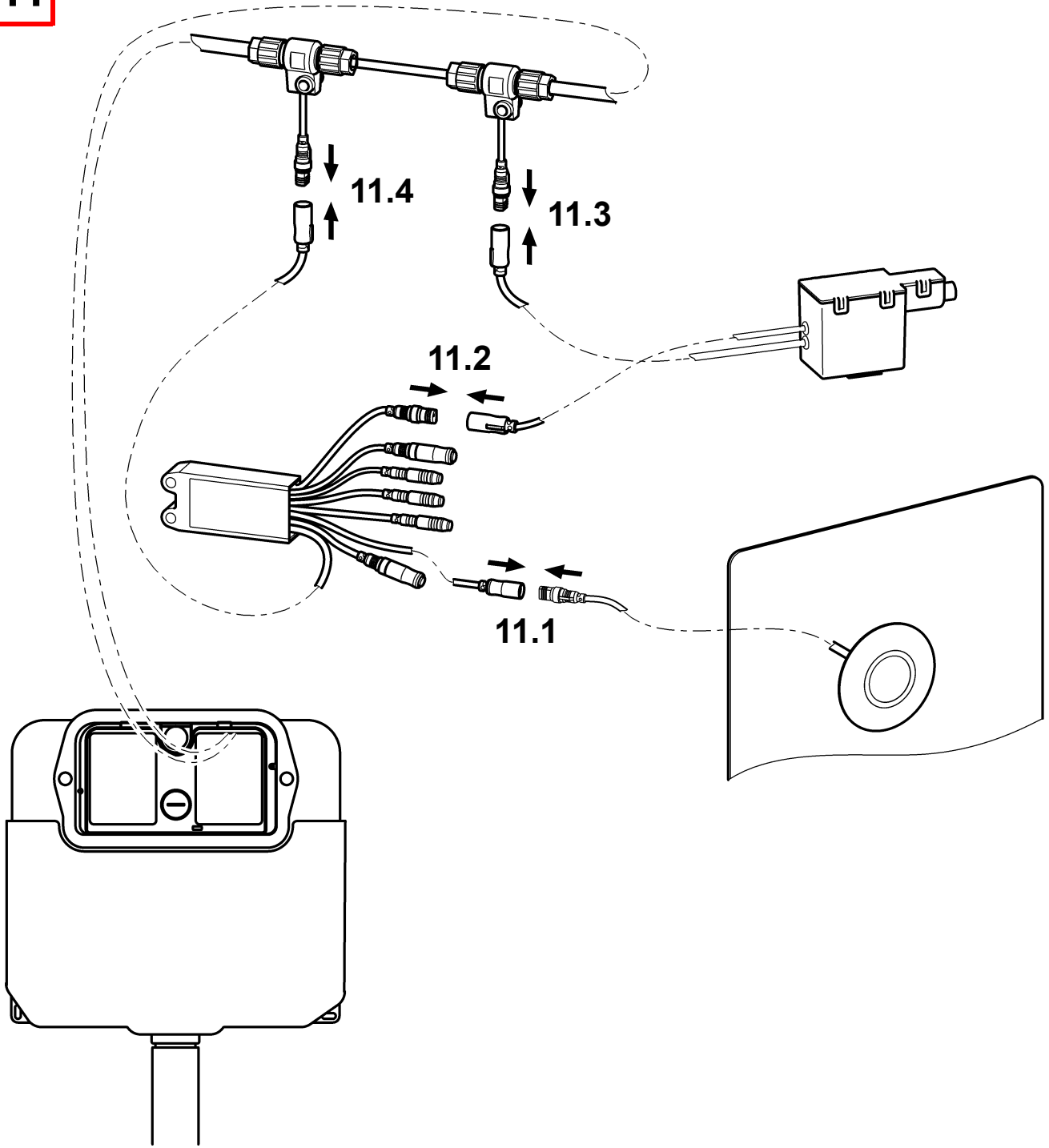

12

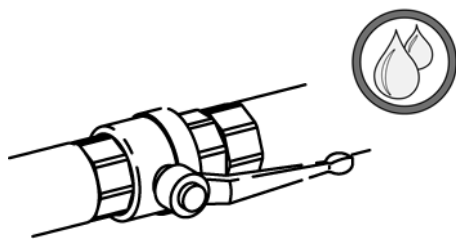

2. Funktion

EN Function

FR Fonctionnement

ES Función

IT Funzionamento

NL Werking

PL Funkcja

SV Funktion

CS Funkce

FI Toiminto

RU Функционирование

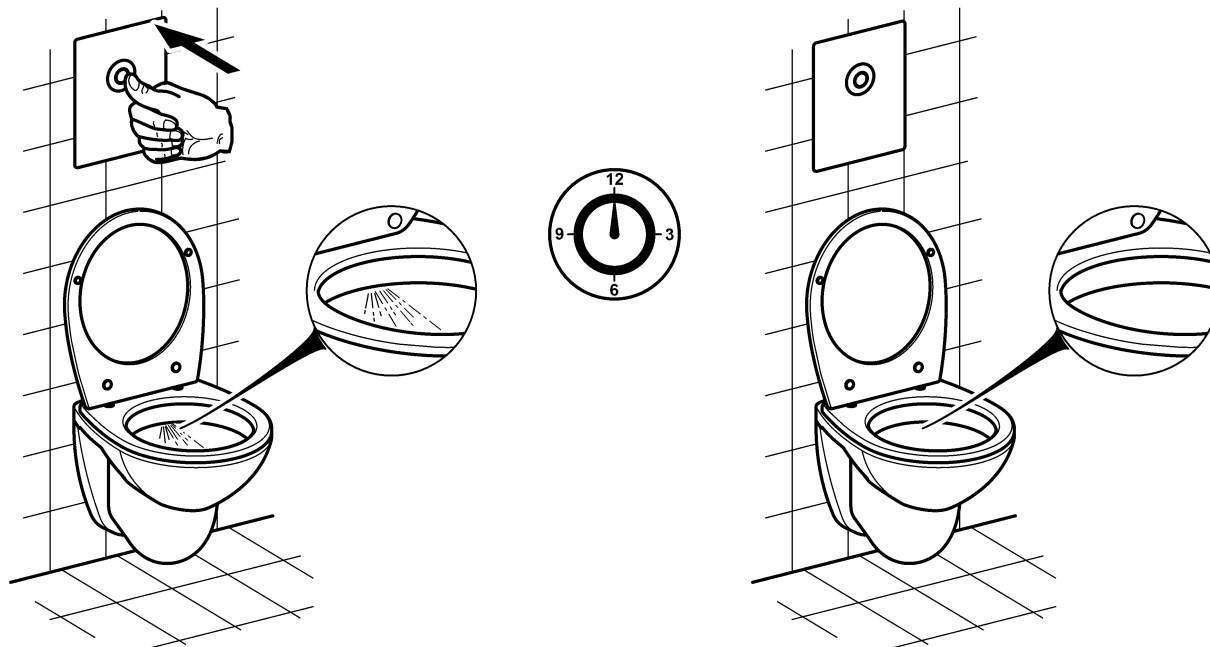

3. Hygienespülung ein-/ausschalten

EN Switching hygiene flushing on/off	NL Hygiënische spoeling in-/uitschakelen	CS Zapněte/vypněte hygienické propláchnutí
FR Activer/désactiver le rinçage hygiénique	PL Włączyć/wyłączyć spłukiwanie higieniczne	FI HygieniahuuhTELun päälle-/ pois päältä kytkeminen
ES Activar/Desactivar el higiene enjuague	SV Koppla hygienspolningen till / från	RU Гигиеническое промывание включить/выключить
IT Attivare/disattivare lo igiene risciacquo		

- EN**
- ▶ Ensure open outlet.
 - ▶ After 24h of non-use, water flows.
- DE**
- ▶ Freien Auslauf gewährleisten.
 - ▶ Nach 24h Nichtbenutzung fließt Wasser.
- FR**
- ▶ Garantir un écoulement libre.
 - ▶ L'eau s'écoule après 24h de non utilisation.
- ES**
- ▶ Garantizar una salida libre.
 - ▶ Si no se realiza ningún uso durante 24 horas, fluye agua.
- IT**
- ▶ Garantire l'erogazione libera.
 - ▶ Dopo 24h di inutilizzo scorre acqua.
- NL**
- ▶ Vrije uitloop garanderen.
 - ▶ Na 24 uur niet te zijn gebruikt stroomt er water.
- PL**
- ▶ Zapewnić swobodny wylot.
 - ▶ Po 24 godz. niekorzystania wypływa woda.
- SV**
- ▶ Garantera fritt avlopp.
 - ▶ Vatten flyter efter 24 timmars användningspaus.
- CS**
- ▶ Zajistěte volný odtok.
 - ▶ Při nepoužívání 24 h nechte téct vodu.
- FI**
- ▶ Vapaan virtauksen takaaminen.
 - ▶ Vesi virtaa 24 tunnin käyttämättömyyden jälkeen.
- RU**
- ▶ Обеспечить беспрепятственный слив
 - ▶ После того, как устройство не используется в течение 24 ч, течёт вода.

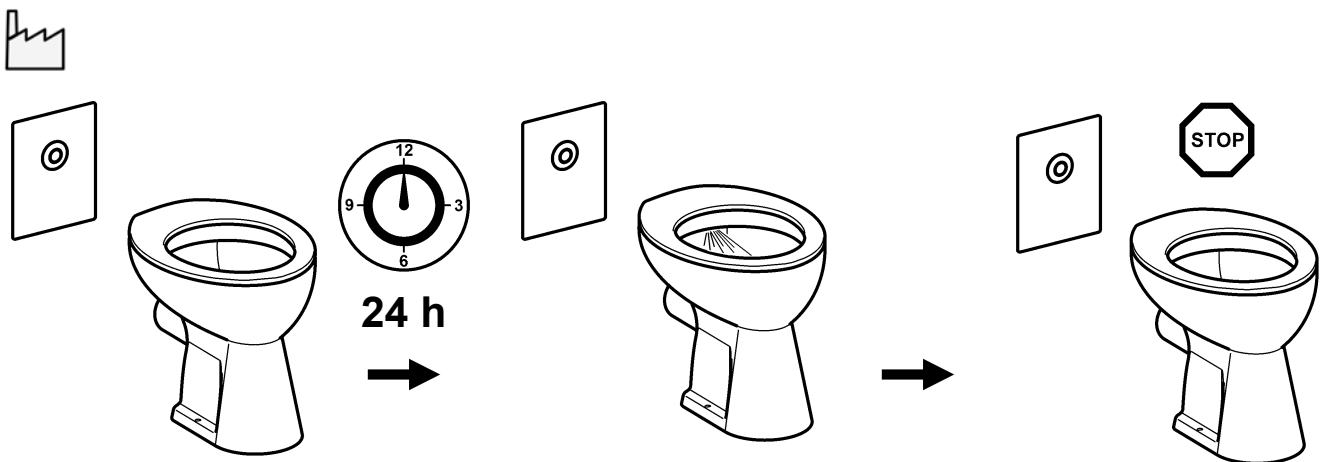



A3000 open

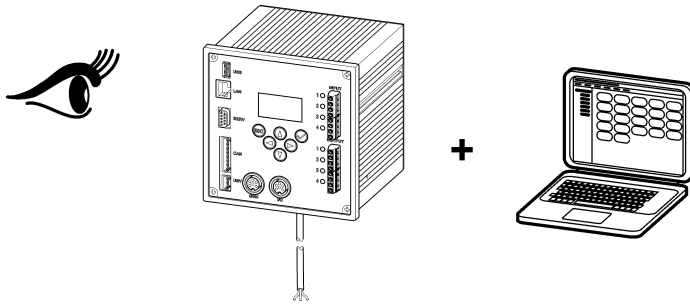

4. Fließzeit einstellen

EN Adjust flow duration

NL Stromingstijd instellen

CS Nastavit dobu průtoku

FR Régler la durée d'écoulement

PL Ustawić czas przepływu

FI Aseta virtausaika

ES Ajustar el tiempo de flujo

SV Ställa in flytförmígan

RU Регулировка времени истечения

IT Impostazione della durata di flusso

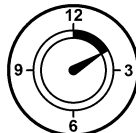

1 s



A3000 open

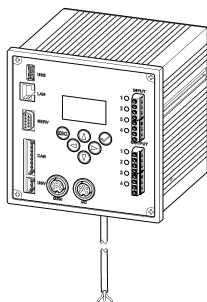

+

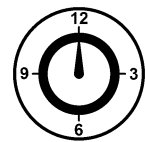
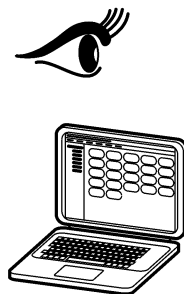

1 - 6500 s

5. Hygienespülung einstellen

EN Setting the hygiene flush	NL Instellen van de hygiënespoeling	CS Nastavení hygienického proplachování
FR Réglage de la rinçage d'hygiène	PL Ustawianie spłukiwania higienicznego	FI Hygieniahuuhtelun säätäminen
ES Ajuste del higiene enjuague	SV Ställa in hygienspolning	RU установив гигиена смыва
IT Impostare lo igiene risciacquo		

- EN**
- ▶ A: Interval adjustable in h
 - ▶ B: Flow duration adjustable in seconds
- DE**
- ▶ A: Intervall einstellbar in h
 - ▶ B: Fließzeit einstellbar in sec
- FR**
- ▶ A: intervalle réglable en h
 - ▶ B: durée d'écoulement réglable en secondes
- ES**
- ▶ A: Intervalo ajustable en horas
 - ▶ B: Tiempo de flujo activable en seg
- IT**
- ▶ A: intervallo impostabile in h
 - ▶ B: durata di flusso impostabile in sec
- NL**
- ▶ A: Interval instelbaar in u
 - ▶ B: Stromingstijd instelbaar in sec.
- PL**
- ▶ A: odstęp czasu regulowany w godzinach
 - ▶ B: czas przepływu regulowany w sekundach
- SV**
- ▶ A: Intervall kan ställas in i timmar
 - ▶ B: Flödestid kan ställas in i sek.
- CS**
- ▶ A: Interval s nastavením v h
 - ▶ B: Doba průtoku s nastavením v sekundách
- FI**
- ▶ A: Aikaväli, asetettavissa h
 - ▶ B: Virtausaika, asetettavissa sek
- RU**
- ▶ A: интервал задается в ч
 - ▶ B: время течения задается в сек.

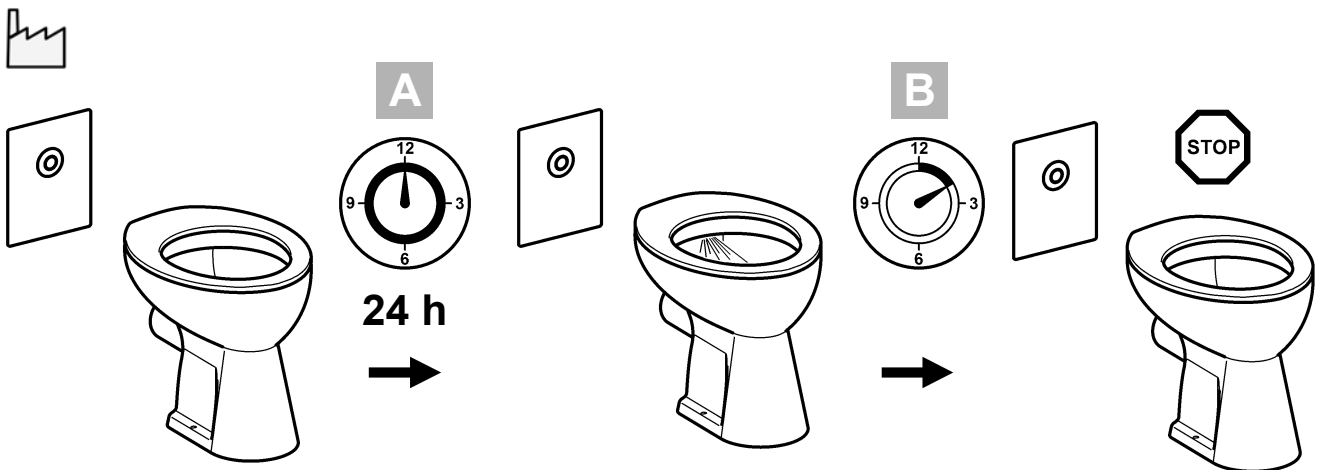



A3000 open

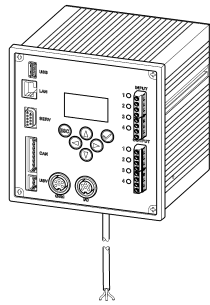

+

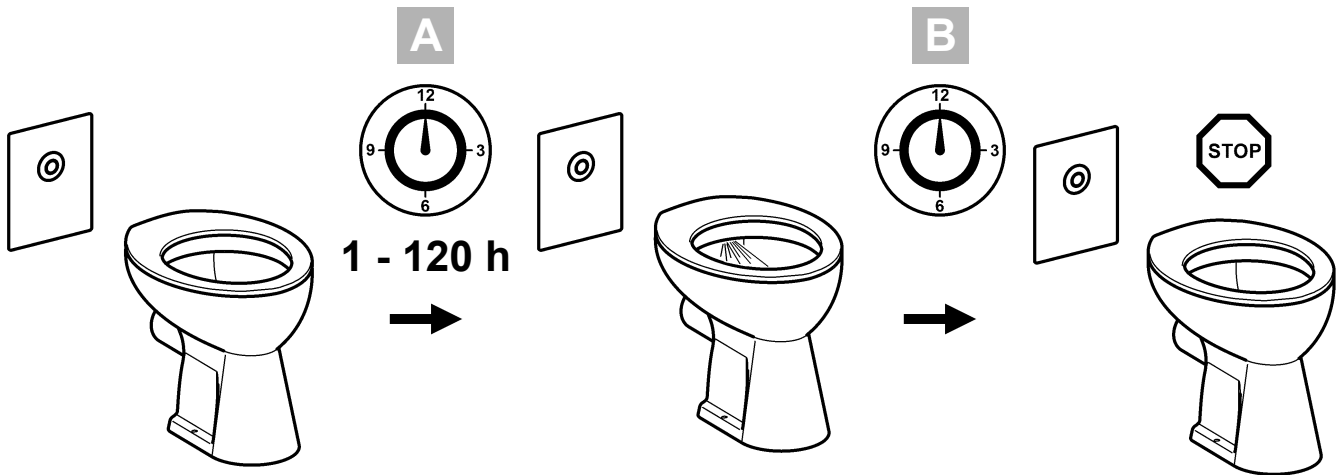

6. Wartung

EN Maintenance
 FR Maintenance
 ES Mantenimiento
 IT Manutenzione

NL Onderhoud
 PL Konserwacja
 SV Underhåll

CS Varování
 FI Huolto
 RU Техническое обслуживание



7.

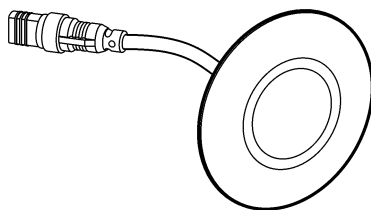

7. Piezo-Taster wechseln

EN Replace piezo button

FR Changer le bouton piézo

ES Cambiar el pulsador piezoeléctrico

IT Cambiare il pulsante piezoelettrico

NL Piëzo-druktoets vervangen

PL Wymienić przycisk piezoelektryczny

SV Byt piezo-tryckknapp

CS Vyměňte piezo spínač

FI Pietsopainike vaihto

RU Замена Пьезовыключатель

1

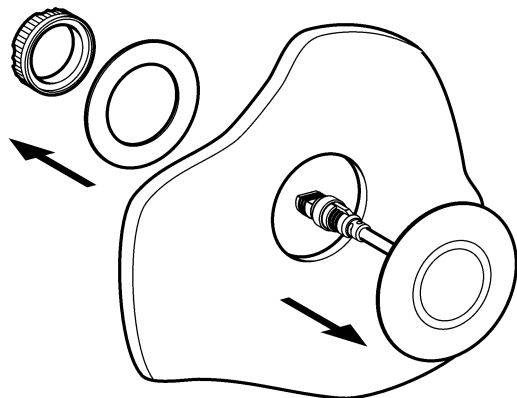

2

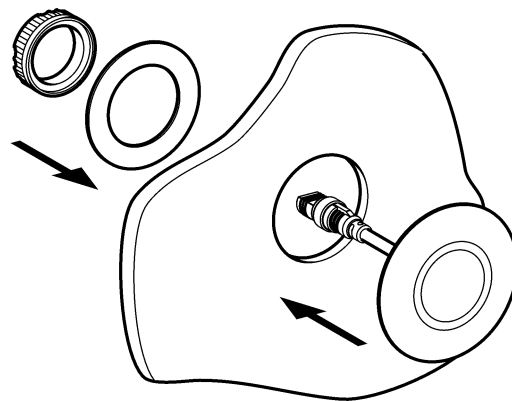

8. Ersatzteile

EN Replacement parts
FR Pièces de rechange
ES Piezas de recambio
IT Pezzi di ricambio

NL Reserveonderdelen
PL Części zamienne
SV Reservdelar

CS Náhradní díly
FI Varaosat
RU Запчасти

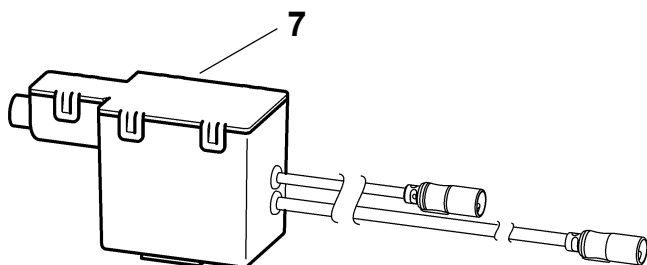
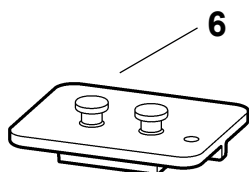
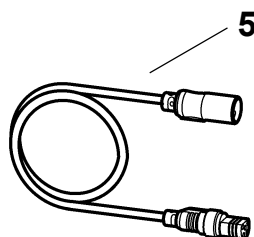
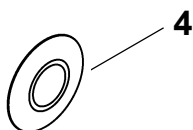
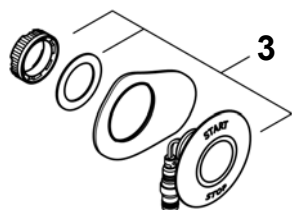
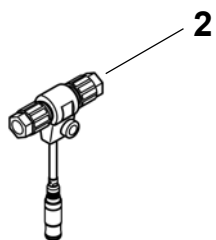
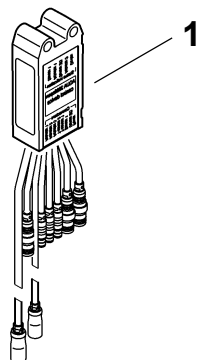

1 2030052935
EA3OP0098

2 2000100853
ZAQUA075

3 2000104441
EAT3O0001

4 2000105712
EAT3O0008

5 2000105694
ZA3OP0004

6 2030035933
EA3OP0049

7 20300722899
ZA3OP0023

9. Zubehör

EN Accessories
FR Accessoire
ES Accesorios
IT Accessori

NL Toebehoren
PL Akcesoria
SV Tillbehör

CS Příslušenství
FI Lisävarusteet
RU принадлежности

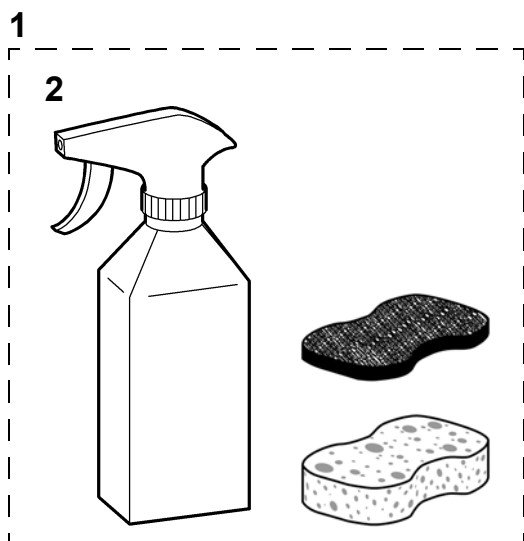

1 2000109019
ZWSPL0024

2 **0,5 l:**
2000105091
ZWSPL0023

3 2000108123
ZA3OP0011

4 2030016282
ZA3OP0022

5 **100 m:**
2000104272
ZAQUA011

25 m:
2000104274
ZAQUA012

6 **100 m:**
2000100801
ZAQUA077

25 m:
2000100852
ZAQUA078

7 2030066229
FLSY0003

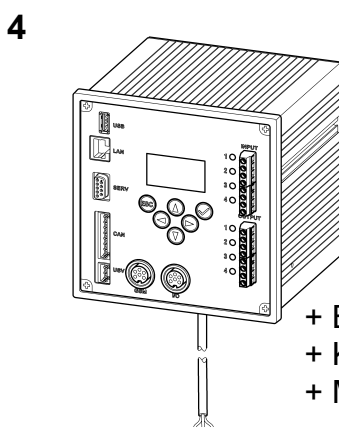
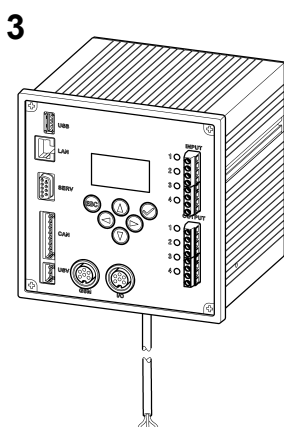

+ BacNet IP
+ KNX IP
+ Modbus IP

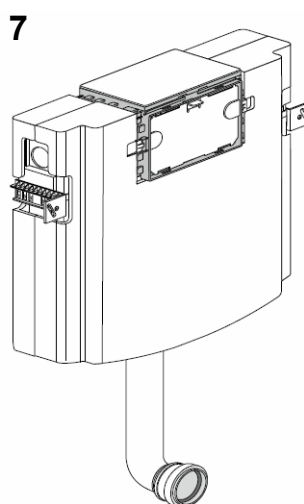
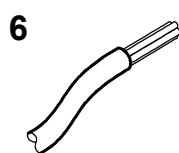
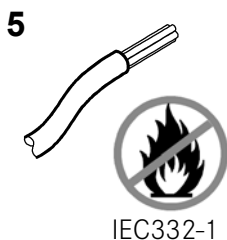

Australia

PR Kitchen and
Water Systems Pty Ltd
Dandenong South VIC 3175
Phone +61 3 9700 9100

Austria

KWC Austria GmbH
6971 Hard, Austria
Phone +43 5574 6735 0

**Belgium, Netherlands &
Luxembourg**

KWC Aquarotter GmbH
9320 Aalst; Belgium
Phone NL +31 (0) 492 728 224
BE/LU +32 (0) 53 60 31 50

Czech Republic

KWC Aquarotter GmbH
14974 Ludwigsfelde, Germany
Phone +49 3378 818 309

France

KWC Austria GmbH
6971 Hard, Austria
Phone +33 800 909 216

Germany

KWC Aquarotter GmbH
14974 Ludwigsfelde
Phone +49 3378 818 0

Italy

KWC Austria GmbH
6971 Hard, Austria
Numero Verde +39 800 789 233

Middle East

KWC ME LLC Ras Al Khaimah,
United Arab Emirates
Phone +971 7 2034 700

Poland

KWC Aquarotter GmbH
14974 Ludwigsfelde, Germany
Phone +48 58 35 19 700

Spain

KWC Austria GmbH
6971 Hard, Austria
Phone +43 5574 6735 211

Switzerland & Liechtenstein

KWC Group AG
5726 Unterkulm, Switzerland
Phone +41 62 768 69 00

Turkey

KWC ME LLC Ras Al Khaimah,
United Arab Emirates
Phone +971 7 2034 700

United Kingdom

KWC DVS Ltd - Northern Office
Barlborough S43 4PZ
Phone +44 1246 450 255

KWC DVS Ltd - Southern Office
Paignton TQ4 7TW
Phone +44 1803 529 021

EAST EUROPE

Bosnia Herzegovina
Bulgaria | Croatia
Hungary | Latvia
Lithuania | Romania
Russia | Serbia | Slovakia
Slovenia | Ukraine

KWC Aquarotter GmbH
14974 Ludwigsfelde, Germany
Phone +49 3378 818 261

SCANDINAVIA & ESTONIA

Finland | Sweden | Norway
Denmark | Estonia

KWC Nordics Oy
76850 Naarajärvi, Finland
Phone +358 15 34 111

OTHER COUNTRIES

KWC Austria GmbH
6971 Hard, Austria
Phone +43 5574 6735 0

